

GLAST Series

▶ GLAST-85-45°/45°-DIF-...

- Recommended measurement distance: 85 mm ± 2 mm
- Determination of the direct reflection behaviour of glossy objects by way of spatial frequency analysis (frequency and amplitude) of a line grid
- Diffuse lighting with three different line grids available (0.5/0.5, 1.0/1.0 or 2.0/2.0)
- Up to 31 states can be saved
- Line detector (512 pixel) incl. projection lens
- RS232 interface (USB or Ethernet adapter is available)
- Haze control
- Brightness correction can be activated (STAT/DYN)
- Several TEACH functions (via PC, PLC, or push button)
- Various evaluation algorithms can be activated
- „BEST HIT“ mode
- Switching state display by means of 5 yellow LEDs
- Parameterizable via Windows® software
- Temperature compensated
- Sturdy aluminum housing

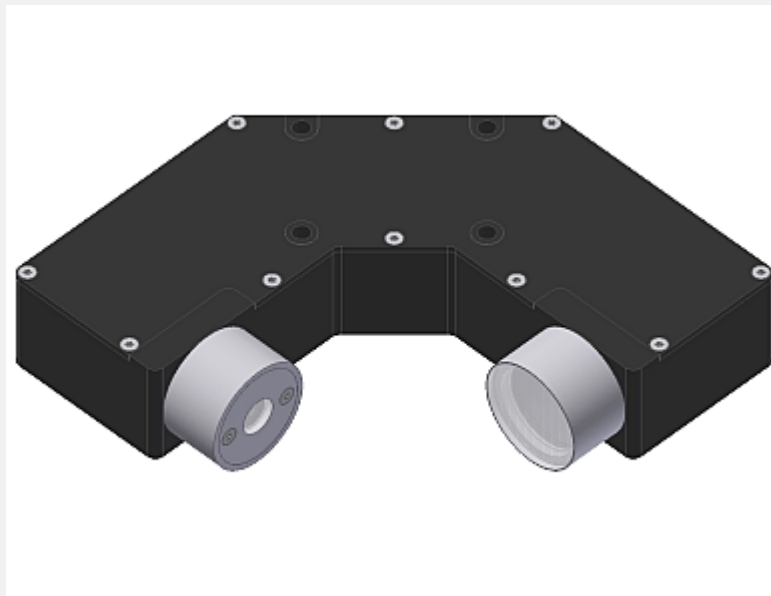

Design

Product name:

GLAST-85-45°/45°-DIF-0.5/0.5

GLAST-85-45°/45°-DIF-1.0/1.0

GLAST-85-45°/45°-DIF-2.0/2.0

(incl. Windows® PC software STRUCT-Scope)

45°/45°: The optical axes each have an angle of 45° with respect to the vertical

Various grid dimensions (line grids) available in front of diffuse lighting:

0.5/0.5 (0.5 mm line thickness, 0.5 mm spacing)

1.0/1.0 (1.0 mm line thickness, 1.0 mm spacing)

2.0/2.0 (2.0 mm line thickness, 2.0 mm spacing)

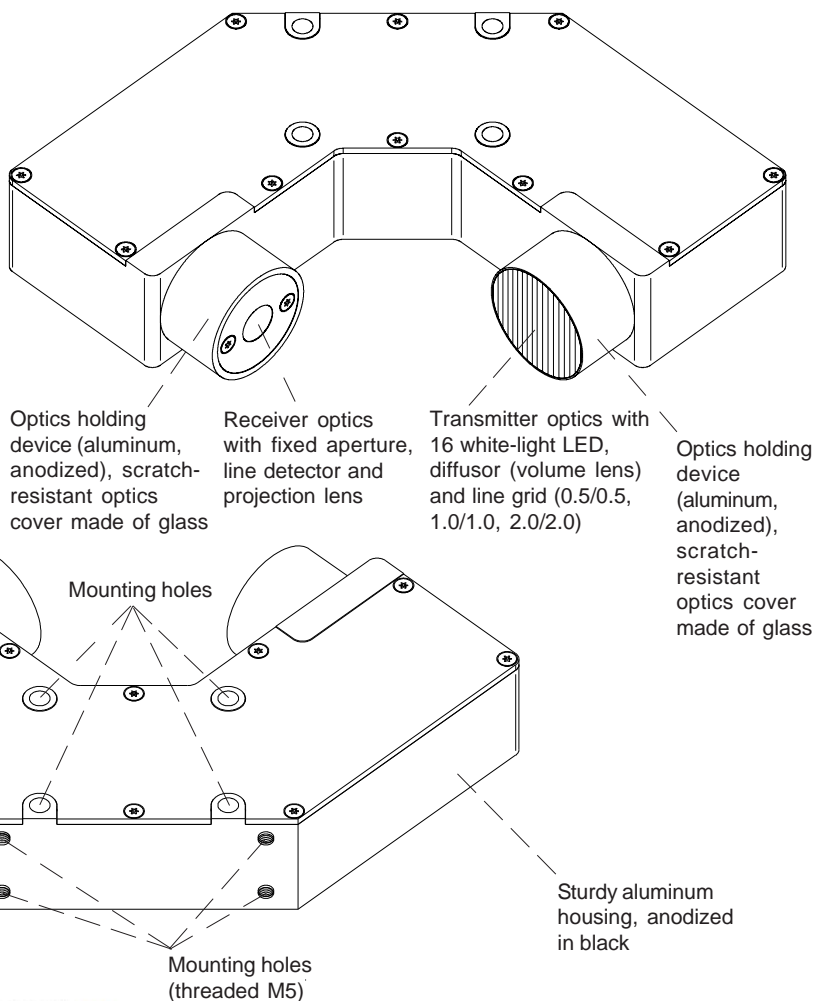

Sensor
Instruments



Technical Data

Model	GLAST-85-45°/45°-DIF-0.5/0.5 GLAST-85-45°/45°-DIF-1.0/1.0 GLAST-85-45°/45°-DIF-2.0/2.0
Voltage supply	+24VDC (± 10%), reverse polarity protected, overcurrent protected
Current consumption	< 500 mA
Max. switching current	100 mA, short circuit proof
Switching state indication	5 yellow LED visualize the physical state of the outputs OUT0 ... OUT4
Inputs digital	1 digital input: IN0 (Pin 3), digital (0V/+24V)
Outputs digital	OUT0...OUT4 (Pin 4..8): digital (0V/+24V), pn-/pnp-able (bright-/dark-switching, can be switched)
Interface	RS232
Pulse lengthening	100 ms ... 1 s (adjustable via PC software)
Averaging	max. 32 values (adjustable via PC software)
Line grid (grid dimension)	Various line grids available: GLAST-85-45°/45°-DIF-0.5/0.5: Line grid with 0.5 mm line thickness and 0.5 mm spacing GLAST-85-45°/45°-DIF-1.0/1.0: Line grid with 1.0 mm line thickness and 1.0 mm spacing GLAST-85-45°/45°-DIF-2.0/2.0: Line grid with 2.0 mm line thickness and 2.0 mm spacing
Max. measuring frequency	typ. 10 Hz
Angle of incidence	The optical axes are inclined each at an angle of 45° from the normal (vertical)
Measuring distance	typ. 85 mm ± 5 mm
Transmitter (light source)	16 super-bright white-light LED, diffusor (volume lens) and line grid
Transmitter control	Can be switched via PC software: AC operation (LED MODE-AC), DC operation (LED MODE-DC),
Receiver	line detector (512 pixel), projection lens, circular aperture (Ø 1 mm)
Exposure time	adjustable via PC software (EXPOSURE TIME)
Detection range	Measuring length typ. 20 mm at a distance of 85 mm
Temperature drift X,Y	$\Delta X/\Delta T$; $\Delta Y/\Delta T$ typ. 0,2 digits/°C (< 0,01% / °C)
Resolution	20mm/4096
Memory capacity	5 spatial frequency spectrums (max. 31 states)
Housing dimensions	LxWxH approx. 204.3 mm x 110.31 mm x 34 mm, without connectors
Housing material	Aluminum, anodized in black (optics holding device: aluminum, anodized)
Enclosure rating	IP64
Connecting cables	to PLC: cab-las8/SPS or cab-las8/SPS-w to PC/RS232 interface: cab-las4/PC or cab-las4/PC-w alternatively: to PC/USB interface: cab-4/USB or cab-4/USB-w alternatively: to PC/Ethernet interface: cab-4/ETH
Type of connector	Connection to PLC: 8-pole fem. connector (Binder 712), connection to PC: 4-pole fem. connector (Binder 707)
Temperature ranges	Operating temperature range: -20°C ... +55°C, storage temperature range: -20°C ... +85°C
EMC test acc. to	DIN EN 60947-5-2

Dimensions

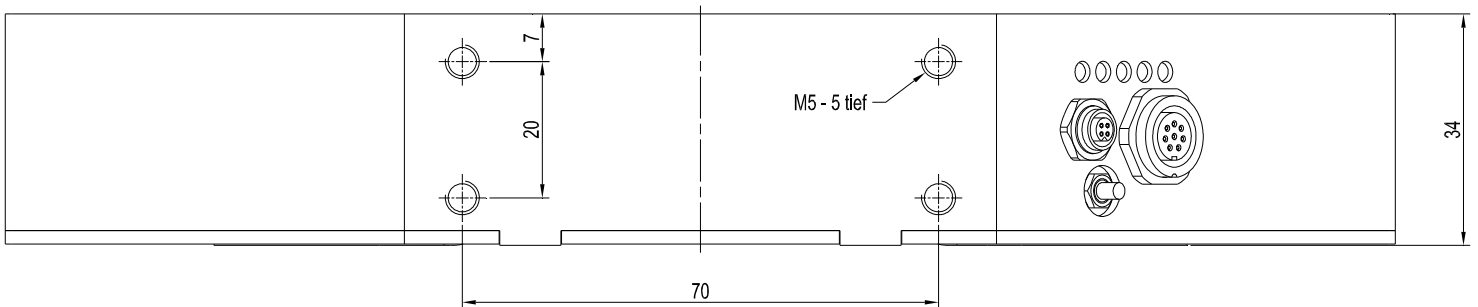
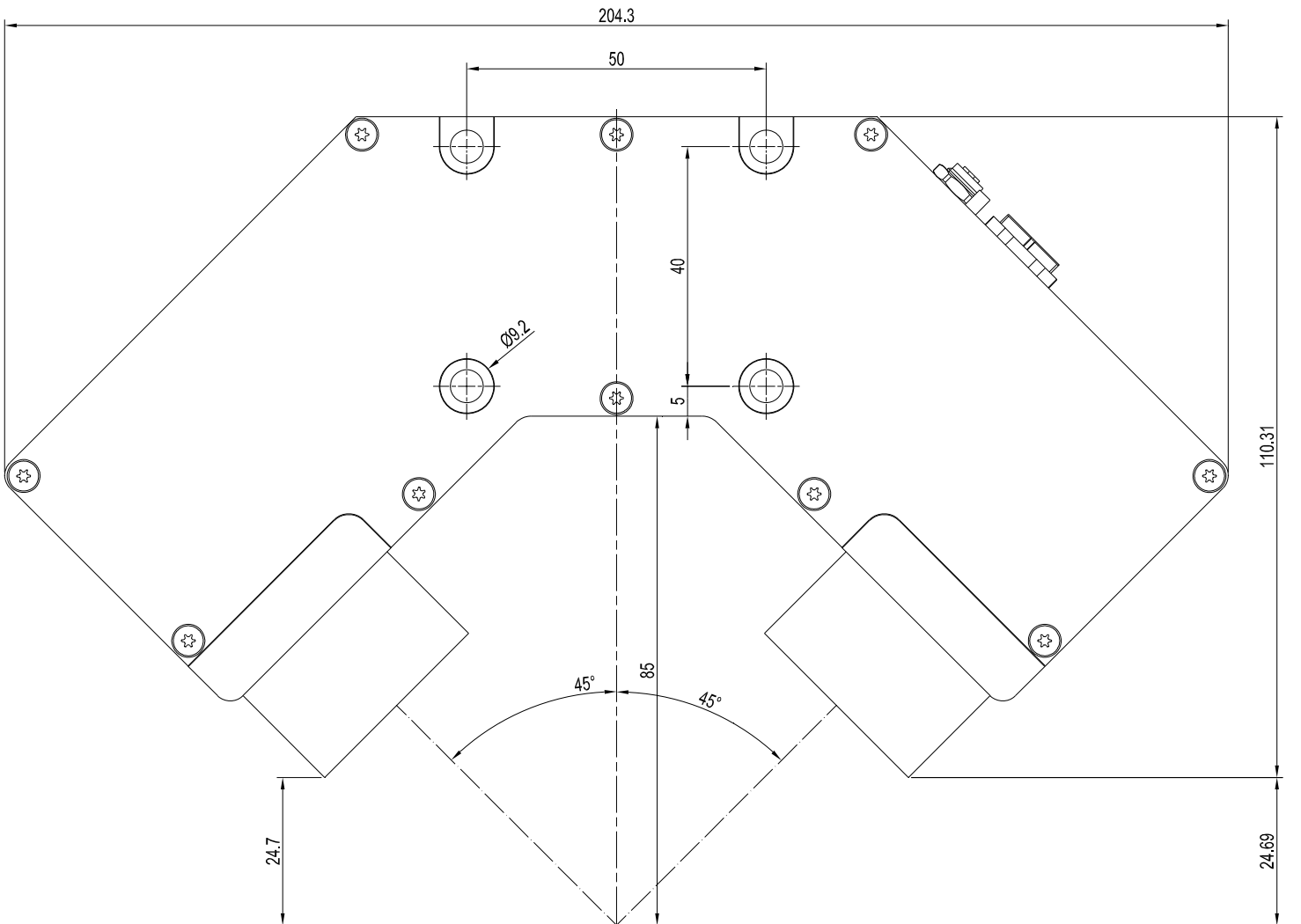

All dimensions in mm



Connector Assignment
Connector assignment:**Connection to PLC:****8-pole fem. connector Binder Series 712**

Pin:	Color:	Assignment:
1	white	GND (0V)
2	brown	+24VDC ($\pm 10\%$)
3	green	IN0
4	yellow	OUT0
5	grey	OUT1
6	pink	OUT2
7	blue	OUT3
8	red	OUT4

Connecting cable:

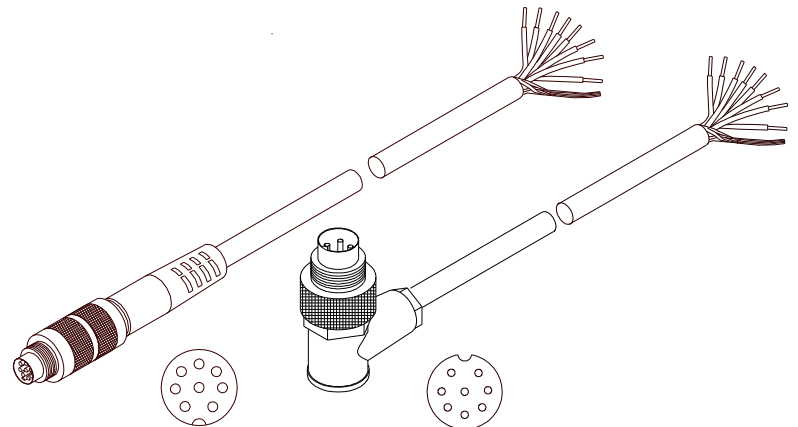
cab-las8/SPS-(length)
 cab-las8/SPS-w-(length) (angle type, 90°)
 (standard length 2m)



cab-las8/SPS-...
 (max. length 25m, outer jacket: PUR)

cab-las8/SPS-w-...
 (max. length 25m, outer jacket: PUR)

Connection to PC:**4-pole fem. connector Binder Series 707**

Pin:	Assignment:
1	+24VDC (+Ub, OUT)
2	GND (0V)
3	RxD
4	TxD

Connection via RS232 interface at the PC:**Connecting cable:**

cab-las4/PC-(length)
 cab-las4/PC-w-(length) (angle type 90°)
 (standard length 2m)

alternative:**Connection via USB interface at the PC:**

Connecting cable (incl. driver software):
 cab-4/USB-(length)
 cab-4/USB-w-(length) (angle type 90°)
 (standard length 2m)

alternative:**Connection to local network via Ethernet bus:**

Adapter (incl. software „SensorFinder“):
 cab-4/ETH-500
 (standard length 0.5m)

Optional: External CAT5 cable, e.g.
 cab-eth/M12D-RJ45-flx-(length)

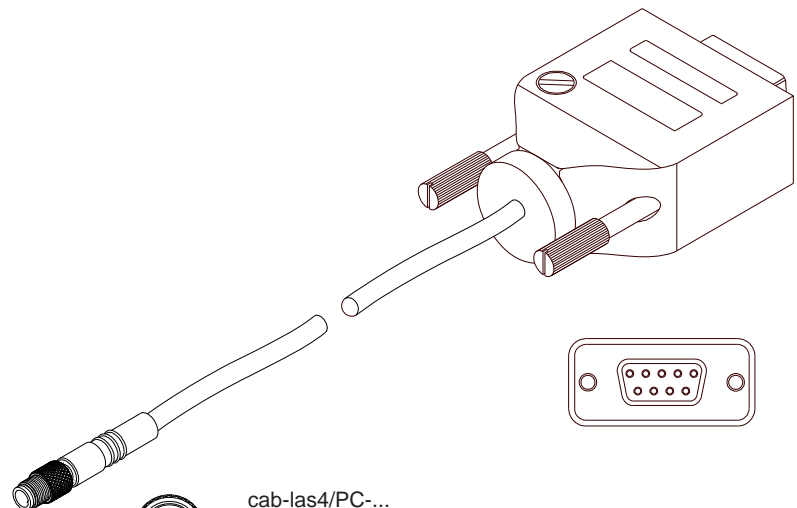

cab-las4/PC-...
 (max. length 10m, outer jacket: PUR) or
 cab-las4/PC-w-... (no picture)
 (max. length 5m, outer jacket: PUR)

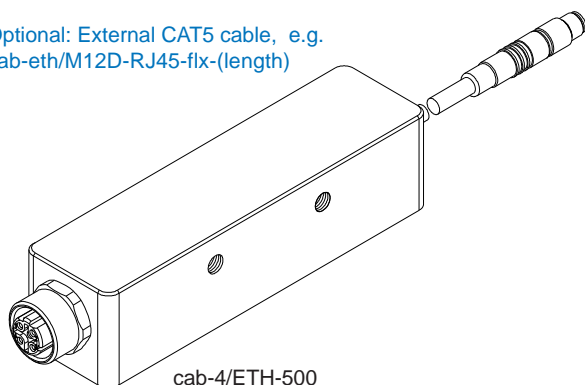

cab-4/ETH-500
 (length 0.5m, outer jacket: PUR)
 4-pole M12 fem. conn. (D-coded)
 for connection of an external
 CAT5 cable, e.g.
 cab-eth/M12D-RJ45-flx-(length)

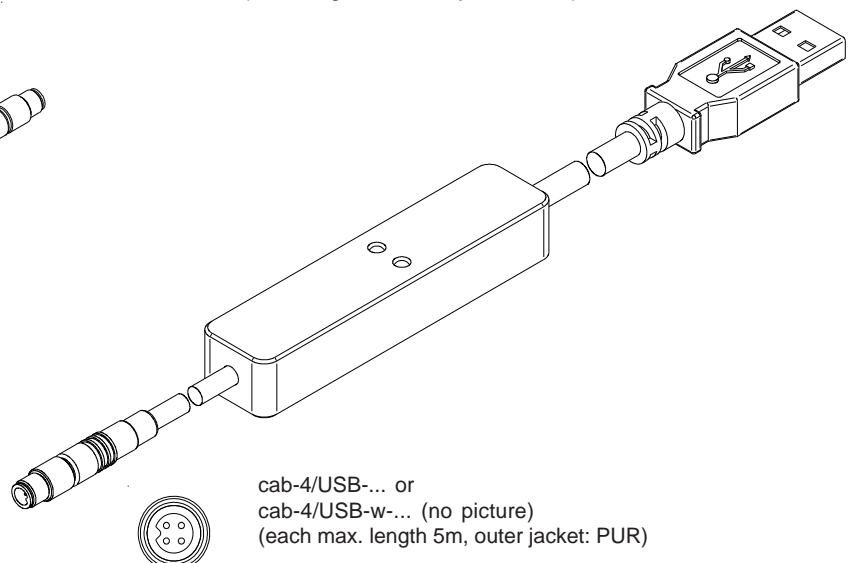

cab-4/USB-... or
 cab-4/USB-w-... (no picture)
 (each max. length 5m, outer jacket: PUR)



Fields of Application
Fields of application of the sensors of GLAST series:

Inline sensors of the GLAST series primarily are used for the inspection of highly reflecting surfaces (e.g. stainless steel panels, aluminum sheets, painted surfaces, plastic films) and transparent objects (films, glass plates, plexiglass plates).

A projection lens projects a line grid onto a line detector with the help of the object to be inspected, which functions as a more or less optimal mirror. Transparent objects are placed close to the line grid, which again is projected onto a line detector by a projection lens. In both cases the quality of the object determines the quality of the video signal at the line detector.

The reflective method operates at an angle of 30° (respectively 45°) each of the optical axes of the transmitter and receiver branch from the vertical, whereas in the through-beam method the object to be inspected stands vertically to the optical axis of the transmitter-receiver setup. In both cases the transmitter-receiver distance is approx. 135 mm.

Three different line grids are available in each case (0.5mm/0.5mm, 1.0mm/1.0mm, and 2.0mm/2.0mm).



Measuring Principle
Measuring principle of the GLAST series sensors:

The GLAST sensor (**GL**oss **ANd** **ST**ructure) among others was developed to inspect the haze behaviour of objects. For this purpose a line grid is placed in front of a homogeneously illuminated area. A projection lens projects this line grid onto the line detector, and the object to be inspected practically functions as a mirror (reflector). The video signal that is available at the receiver side then provides information about the quality of the "mirror", i.e. about the reflection properties of the object surface. If the haze ratio increases, the video signal "flattens", which also results in a change of the spatial frequency spectrum, the line grid that is projected on the line detector. This means that the higher frequencies are less present, and the amplitudes generally decrease.

The GLAST sensor in principle is a line camera that is equipped with a controllable diffuse light unit (16 white light LED + diffusor + line grid). The detection range (line) is 20 mm at a distance of 85 mm from the sensor body (see dimensions) and runs in longitudinal extension of the sensor. The line-shaped section of the surface to be inspected (approx. 20 mm x 0.5 mm) is projected onto the line detector by the projection lens (receiver optics). The video signal that is generated by the line detector is converted into a spatial frequency spectrum by way of suitable algorithms in the sensor's internal controller. This means that a signal is thus available that provides information about the haze ratio of the surface. Up to 5 spatial frequency spectrums and up to 31 states can be saved in the sensor. During the inspection process the current spatial frequency spectrum is compared with the spatial frequency spectrums saved in the memory, and the most similar spatial frequency spectrum is searched. Amplitudes, frequency, and harmonic waves also are compared.

With the help of the surface to be inspected (object surface) the line grid is reflected in the direction of the projection lens and through the projection optics is projected onto the line detector. The video signal of the line detector and therefore also the spatial frequency spectrum changes depending on the quality of the "mirror" (i.e. on the reflection properties of the object surface).

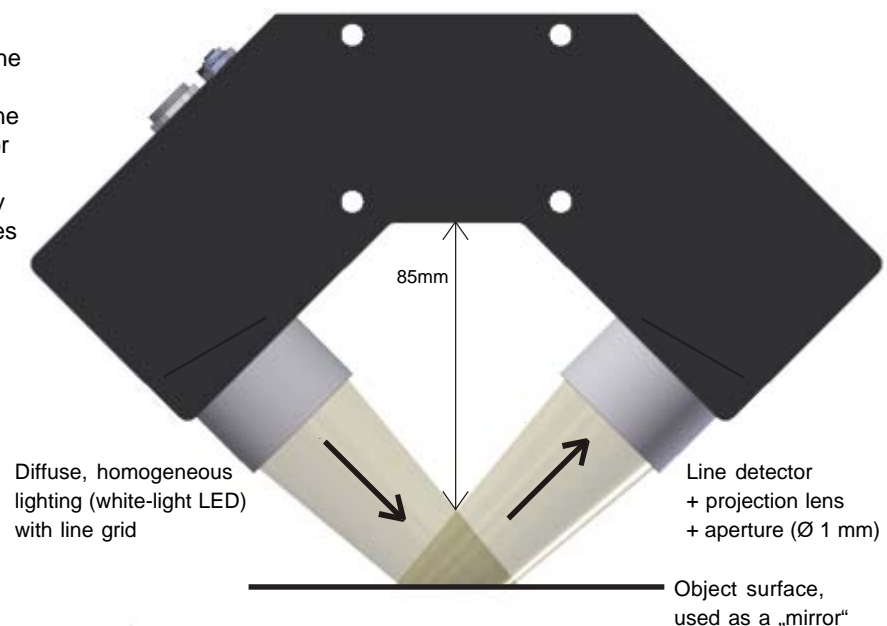



Visualization of the state code:

The state code is visualized by means of 5 yellow LEDs at the housing of the GLAST sensor. The state code that is indicated at the LED display simultaneously is provided in binary mode (OUT BINARY) as 5-bit binary information at digital outputs OUT0 ... OUT4 of the 8-pole PLC connector.

The GLAST sensor is able to process a maximum of 31 states (code 0 ... 30) corresponding to the individual rows in the TEACH TABLE. The sensor indicates an "error" or a "not detected state" by turning on all the LEDs (digital outputs OUT0 ... OUT4 at HIGH level).

Besides, the sensor can store a maximum of 5 spatial frequency spectrums for correlation evaluation.

A maximum of 5 teach states (no. 0, 1, 2, 3, 4) are permitted in DIRECT mode (OUT DIRECT HI or OUT DIRECT LO). If the selector switch is set to DIRECT HI, the corresponding digital output is HI and the other four are LO. If no state was detected, the digital outputs are in LO state (no LED is on).

If the selector switch is set to DIRECT LO, the corresponding digital output is LO and the other four are HI. If no state was detected, the digital outputs are in HI state (all LEDs are on).

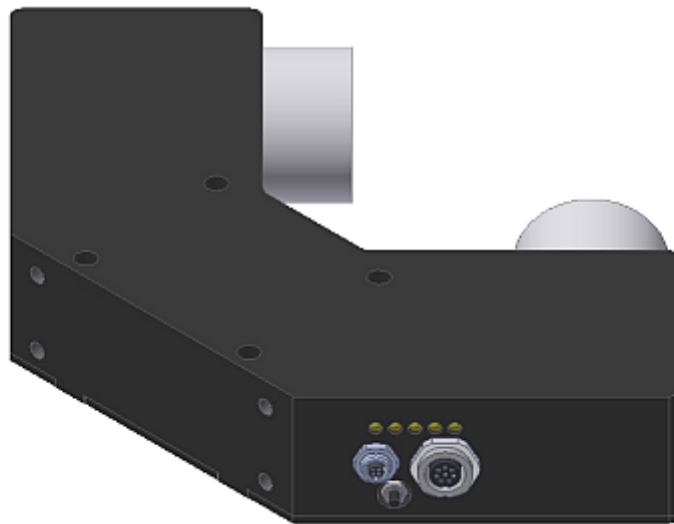

LED Display

LED display:

The state code is visualized by means of 5 yellow LEDs at the housing of the GLAST sensor. The state code indicated at the LED display is output as 5-bit binary information at the digital outputs OUT0 ... OUT4 of the 8-pole PLC connector.

In the DIRECT mode the maximum number of state codes to be taught is 5. These 5 state codes can be directly output at the 5 digital outputs. The respective detected state code is displayed by means of the 5 yellow LEDs at the housing of the GLAST sensor.

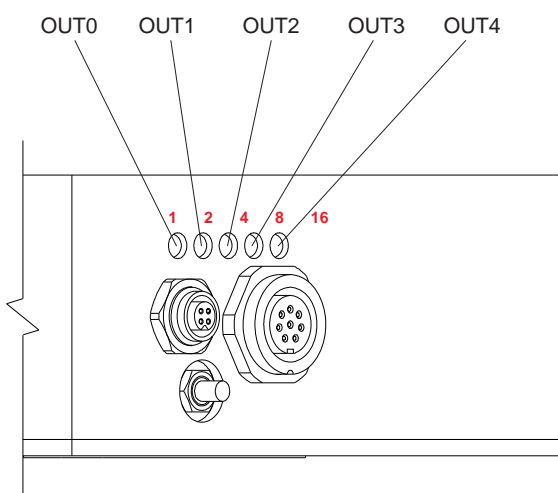

○ ○ ○ ○ ○ 0	● ○ ○ ○ ○ 1	○ ● ○ ○ ○ 2
● ● ○ ○ ○ 3	○ ○ ● ○ ○ 4	● ○ ● ○ ○ 5
○ ● ● ○ ○ 6	● ● ● ○ ○ 7	○ ○ ○ ● ○ 8
● ○ ○ ● ○ 9	○ ● ○ ● ○ 10	● ● ○ ● ○ 11
○ ○ ● ● ○ 12	● ○ ● ● ○ 13	○ ● ● ● ○ 14
● ● ● ○ ○ 15	○ ○ ○ ○ ● 16	● ○ ○ ○ ● 17
○ ● ○ ○ ● 18	● ● ○ ○ ● 19	○ ○ ● ○ ● 20
● ○ ● ○ ● 21	○ ● ● ○ ● 22	● ● ● ○ ● 23
○ ○ ○ ● ● 24	● ○ ○ ● ● 25	○ ● ○ ● ● 26
● ● ○ ● ● 27	○ ○ ● ● ● 28	● ○ ● ● ● 29
○ ● ● ● ● 30	● ● ● ● ● Fehler bzw. „nicht erkannt“	



Parameterization

Software STRUCT-Scope: GENERAL-PARAMETER 1 and VIDEO & SPEC

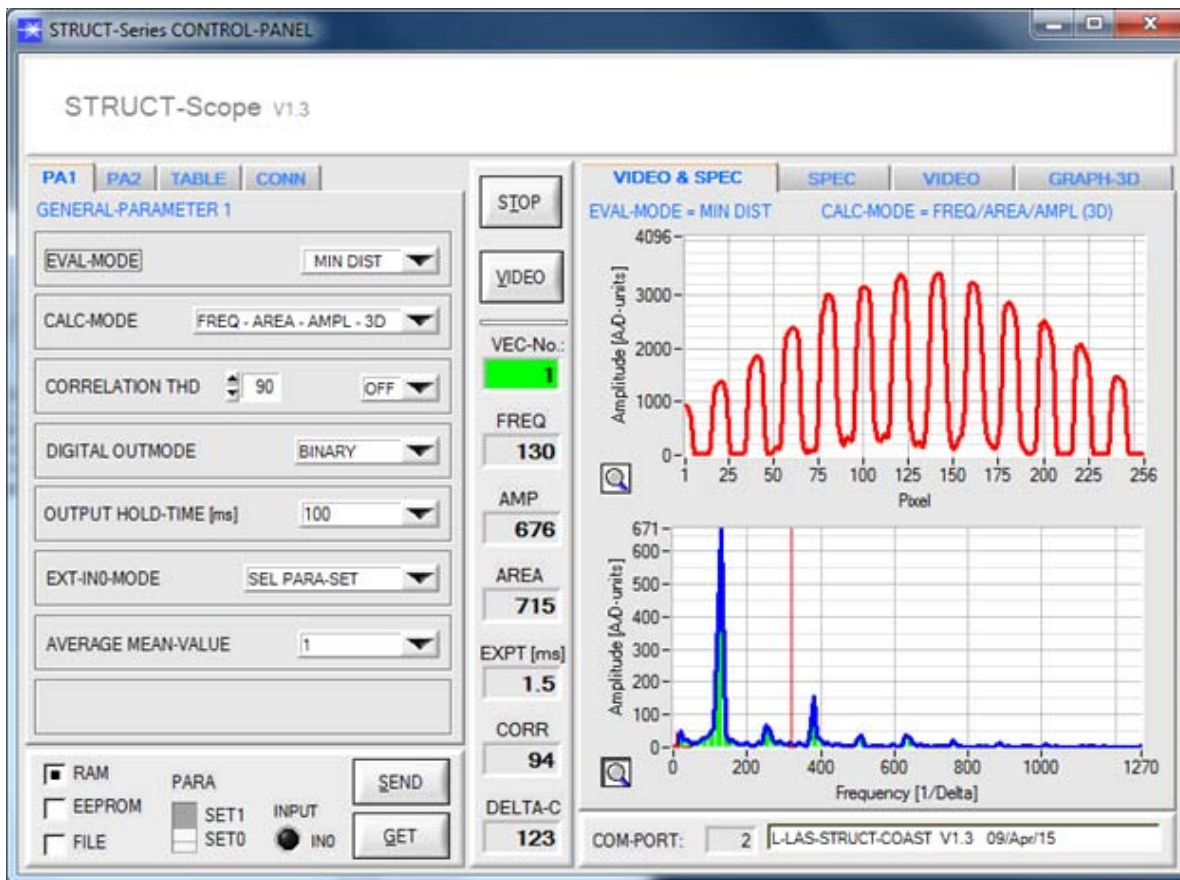

The RS232 interface (tabs PA1, PA2, and TABLE) is used to set sensor parameters such as:

EVAL-MODE:	Evaluation mode in the 2D/3D number range
CALC-MODE:	Calculation mode of information from the spectrum
CORRELATION THD:	Threshold for use in correlation calculation
DIGITAL OUTMODE:	Control mode of digital outputs
OUTPUT HOLD-TIME:	Output hold time
EXT-IN0-MODE:	Setting of the external trigger mode. (CONTINUOUS, TRIGG-IN0 L/H, TRIGG IN0 HIGH, SEL PARA-SET)
AVERAGE MEAN-VALUE:	Setting of averaging at the sensor (possible values: 1, 2,4,8,16 or 32)

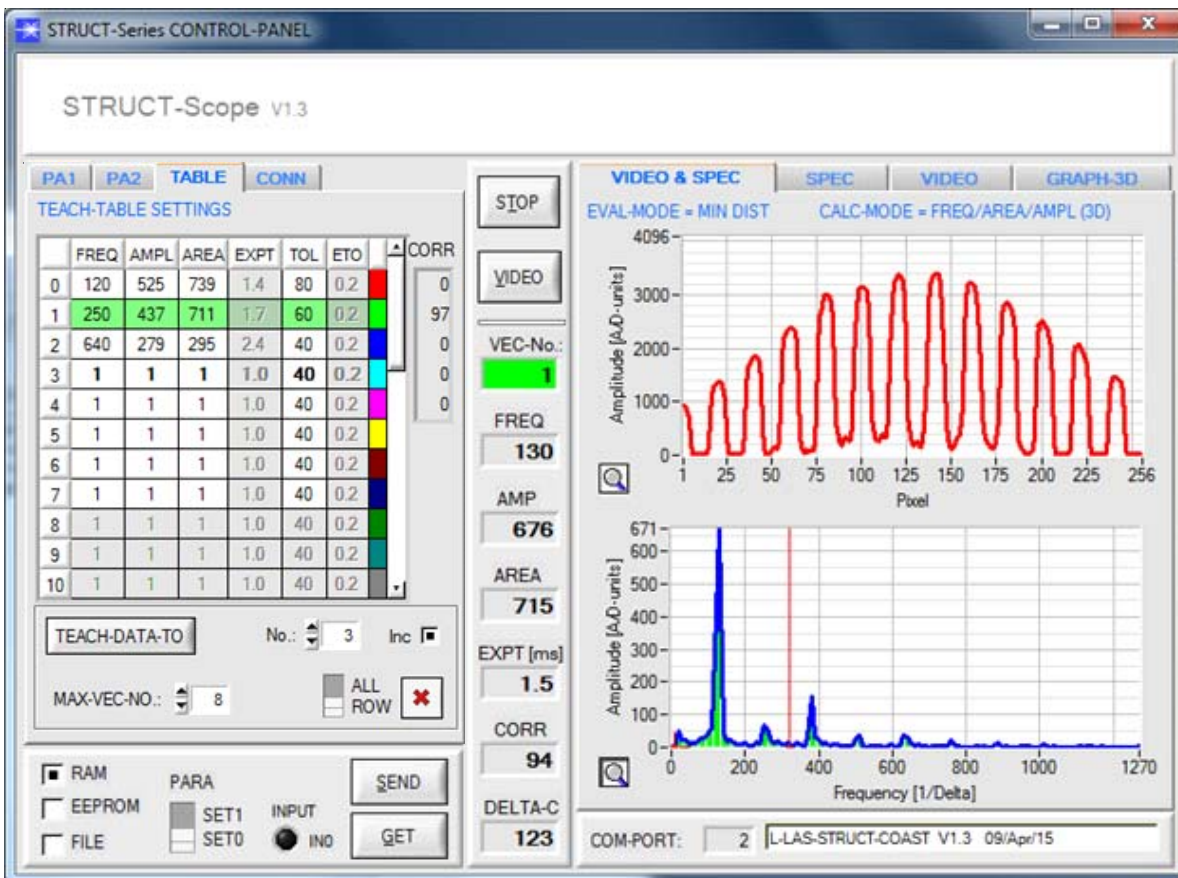

Parameterization
Software STRUCT-Scope: TEACH-TABLE**TEACH-TABLE:**

Maximum of 31 structure vectors (vector entries) for the differentiation of 31 different structures, setting of tolerances for the evaluation values (TOL) from the spectrum, and setting of the tolerance for the exposure time (ETO).
 Display of the correlation value **for max. 5 comparison spectrums** (spatial frequency spectrums).
 TEACH-IN button for teaching the current spectrum to the teach table.

Display and input of the following evaluation values:

FREQ: Frequency
 AMPL: Amplitude
 AREA: Normed area ratio calculated from the frequency spectrum
 EXPT: Exposure time of the respective structure
 TOL: Tolerance for frequency and amplitude
 ETO: Tolerance for exposure time



Firmware Update

Firmware update by means of the software „FirmwareLoader“:

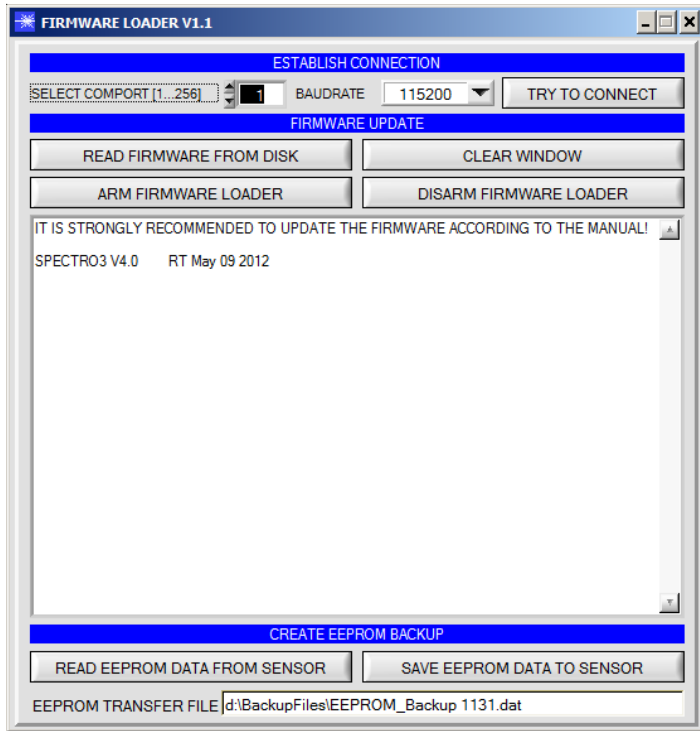

The software „Firmware Loader“ allows the user to perform an automatic firmware update. The update will be carried out through the RS232 interface.

An initialisation file (xxx.ini) and a firmware file (xxx.elf.S) are required for performing a firmware update. These files can be obtained from your supplier. In some cases an additional firmware file for the program memory (xxx.elf.p.S) is also needed, and this file will be automatically provided together with the other two files.

Application Examples

Haze control of stainless steel plates

The haze of stainless steel surfaces should be controlled. For this purpose an optical sensor type GLAST-85-30°/30°-DIF-2.0/2.0 is used. At this, the distance to the stainless steel surface is approximately 85 mm and the detected line has a length of around 20 mm at this distance. The haze can be proper detected, as shown in the screen shots.

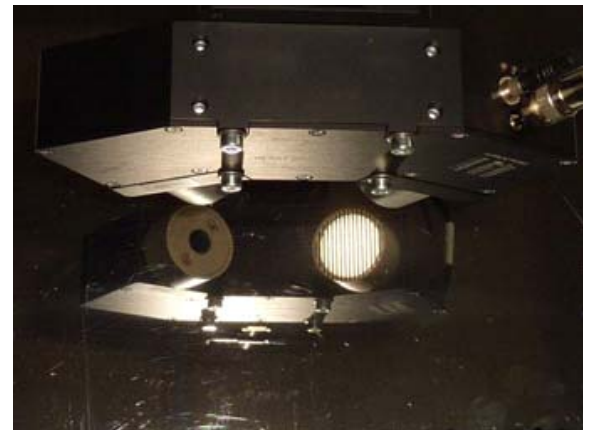
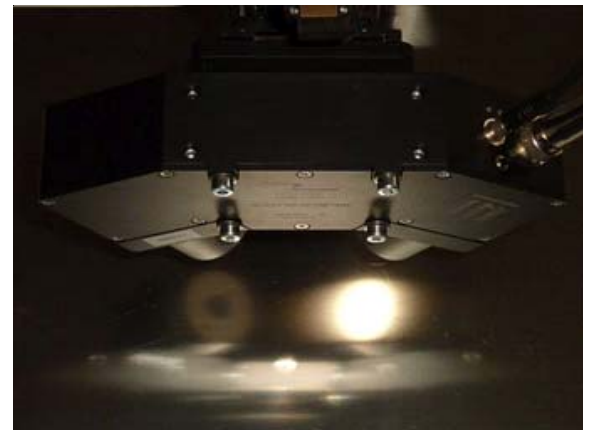
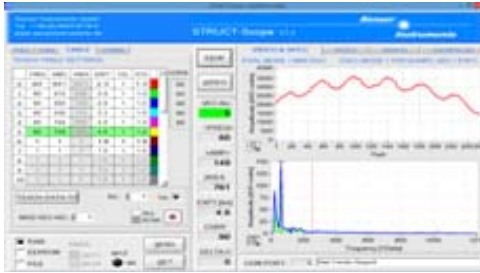
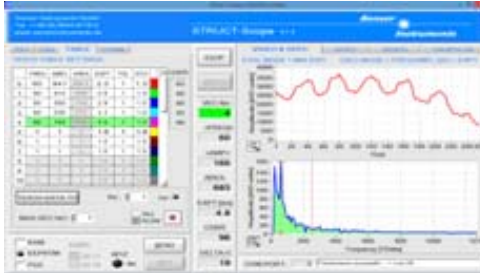
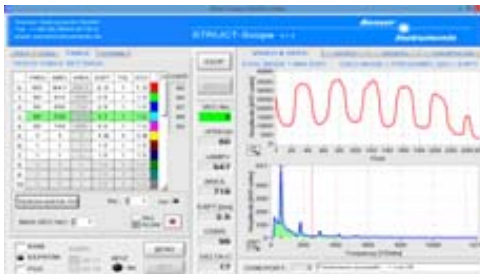
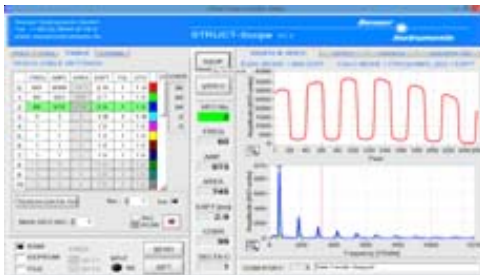
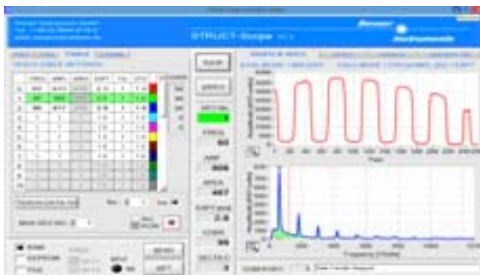

Application Examples

Differentiation of diverse hazy metal parts

Diverse hazy metal components should be differentiated. For this purpose, a haze sensor type GLAST-85-30°/30°-DIF-1.0/1.0 is used.

At this, the sensor is arranged at a distance of around 85 mm to the object. Furthermore, the detecting range is approximately 20 mm in length. The metal parts can be proper haze differentiated as shown in the screen shots.

