

# L-LAS Series

## ▶ L-LAS-TB-28-T-AL L-LAS-TB-28-R-AL

- Line laser <math><0.39\text{ mW}</math>, wave length 670 nm, laser class 1
- Visible laser line, light curtain 35 mm
- Measuring range typ. 28 mm
- Resolution up to 2  $\mu\text{m}$  (depends on selected scan frequency)
- Working distance up to 2000 mm
- Integrated interference filter
- CCD line detector with 2048 pixel, 16384 subpixel
- RS232 user interface (USB or Ethernet converter optional)
- 2 digital inputs, 3 digital outputs (HIGH/LOW/GO)
- Analog output adjustable via software (0 ... +10V or 4 ... 20mA)
- Max. scan frequency selectable via software (800 Hz, 1.4 kHz or 2 kHz)
- Multi-edge evaluation of the video signal
- Switching state indication via 4 two-color LEDs (2x red/grn, 2x yel/grn)



### Design

#### Product name:

**L-LAS-TB-28-T-AL** (Transmitter)  
**L-LAS-TB-28-R-AL** (Receiver)  
 (Receiver incl. Windows® PC software  
 L-LAS-TB-Scope as of V5.0)

**Accessories:** (cf. pages 8-9)

**TRA-L-LAS-TB-CL-...** (mounting plate)  
**ABL-TB-28-CL** (blast air top-part)

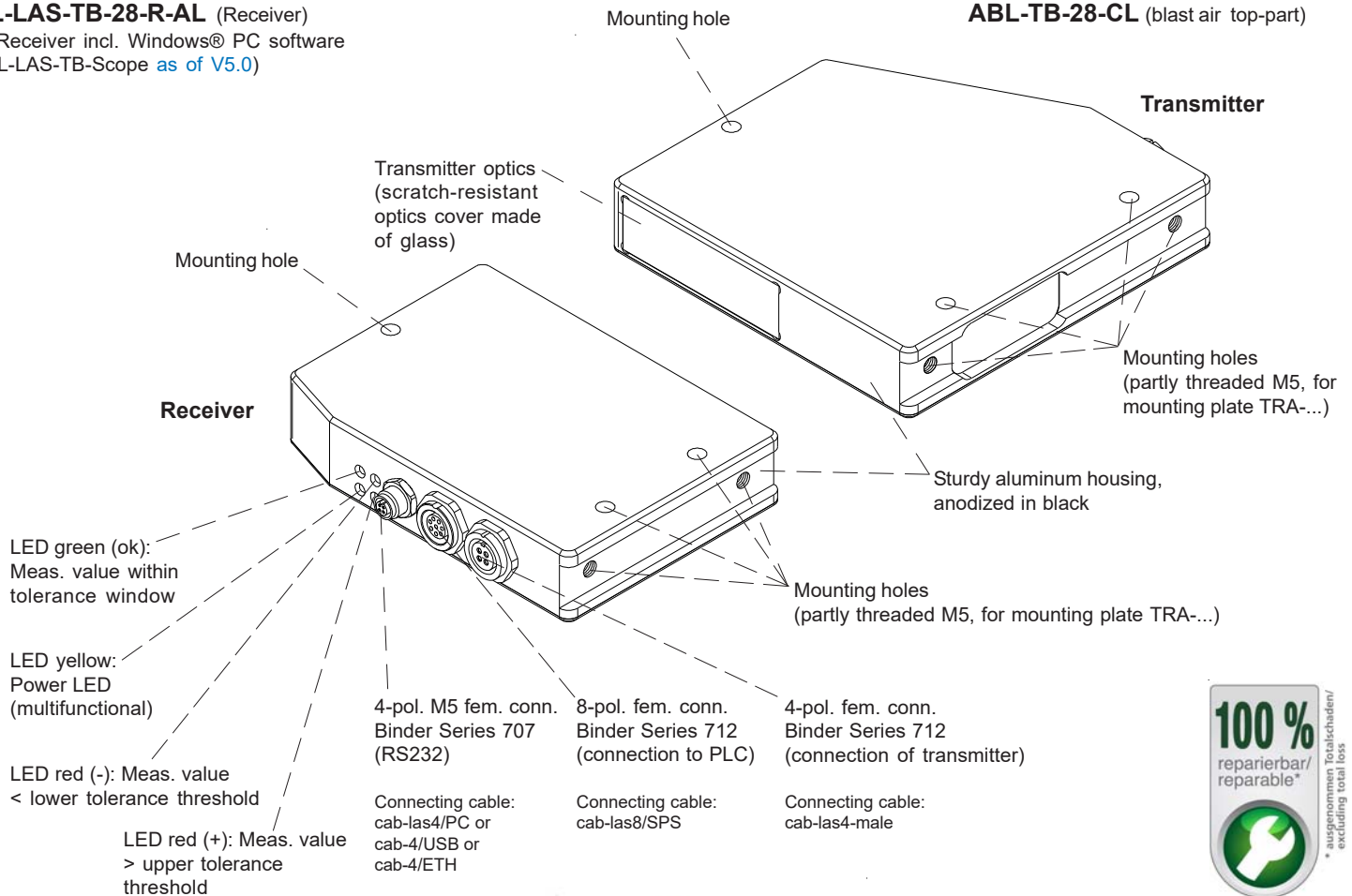



**Technical Data**

Type	L-LAS-TB-28-T-AL L-LAS-TB-28-R-AL
Laser	Semiconductor laser, 670 nm, DC operation, < 0.39 mW max. opt. power, laser class 1 acc. to DIN EN 60825-1. The use of these laser sensors therefore requires no additional protective measures.
Working distance	distance transmitter/receiver: up to 2000 mm
Measuring range	typ. 28 mm
Resolution	typ. 2 µm (Normal Speed mode), typ. 4 µm (Fast Speed mode), typ. 6 µm (High Speed mode)
Reproducibility	typ. ± 2 µm (Normal Speed mode), typ. ± 4 µm (Fast Speed mode), typ. ± 6 µm (High Speed mode)
Linearity	typ. 0.08% FSR (full scale range)
Optical filter	Interference filter
Analog output (1x)	voltage output 0 ... +10V or current output 4 ... 20mA (adjustable under Windows® via PC)
Digital outputs (3x) (OUT0, OUT1, OUT2)	OUT0: (-) Measuring value < lower tolerance threshold OUT1: (+) Measuring value > upper tolerance threshold OUT2: (ok) Measuring value within tolerance window pnp bright-switching/npn dark-switching or pnp dark-switching/npn bright-switching, adjustable under Windows®, 100 mA, short-circuit proof
Digital inputs (2x) (IN0, IN1)	IN0: Extern trigger, IN1: Teach/Reset (double function) input voltage +Ub/0V, with protective circuit
Voltage supply	+24VDC (± 10%)
Sensitivity setting	under Windows® via PC
Laser power correction	adjustable under Windows® via PC
Current consumption	typ. 200 mA
Enclosure rating	electronics: IP54, optics: IP67
Operating temperature range	-10°C ... +50°C
Storage temperature range	-20°C ... +85°C
Housing material	aluminum, anodized in black
Housing dimensions	transmitter: LxWxH approx. 100 mm x 98 mm x 20 mm (without flange connectors) receiver: LxWxH approx. 70 mm x 98 mm x 20 mm (without flange connectors)
Connectors receiver	8-pole circular female connector type Binder 712 (PLC/Power) 4-pole M5 circular female connector type Binder 707 (RS232/PC) 4-pole circular female connector type Binder 712 (connection to transmitter)
Connector transmitter	4-pole circular female connector type Binder 712 (connection to receiver)
LED display	LED red (+): measuring value > upper tolerance threshold LED green (ok): measuring value within tolerance window LED red (-): measuring value < lower tolerance threshold LED yellow: multifunctional
EMC test acc. to	DIN EN 60947-5-2
Scan frequency	Normal Speed mode (high resolution = 2 µm): max. 800 Hz Fast Speed mode (half resolution = 4 µm): max. 1.4 kHz High Speed mode (low resolution = 6 µm): max. 2 kHz can be switched under Windows®
Max. switching current	100 mA, short-circuit proof
Interface	RS232, parameterisable under Windows®
Connecting cables	Connection to PC: cab-las4/PC or cab-4/USB or cab-4/ETH Connection to PLC: cab-las8/SPS or cab-las8/SPS-w Connecting cable transmitter/receiver: cab-las4-male
Output polarity	bright/dark switching, can be switched under Windows®

Dimensions

**L-LAS-TB-28-T-AL**  
(Transmitter)

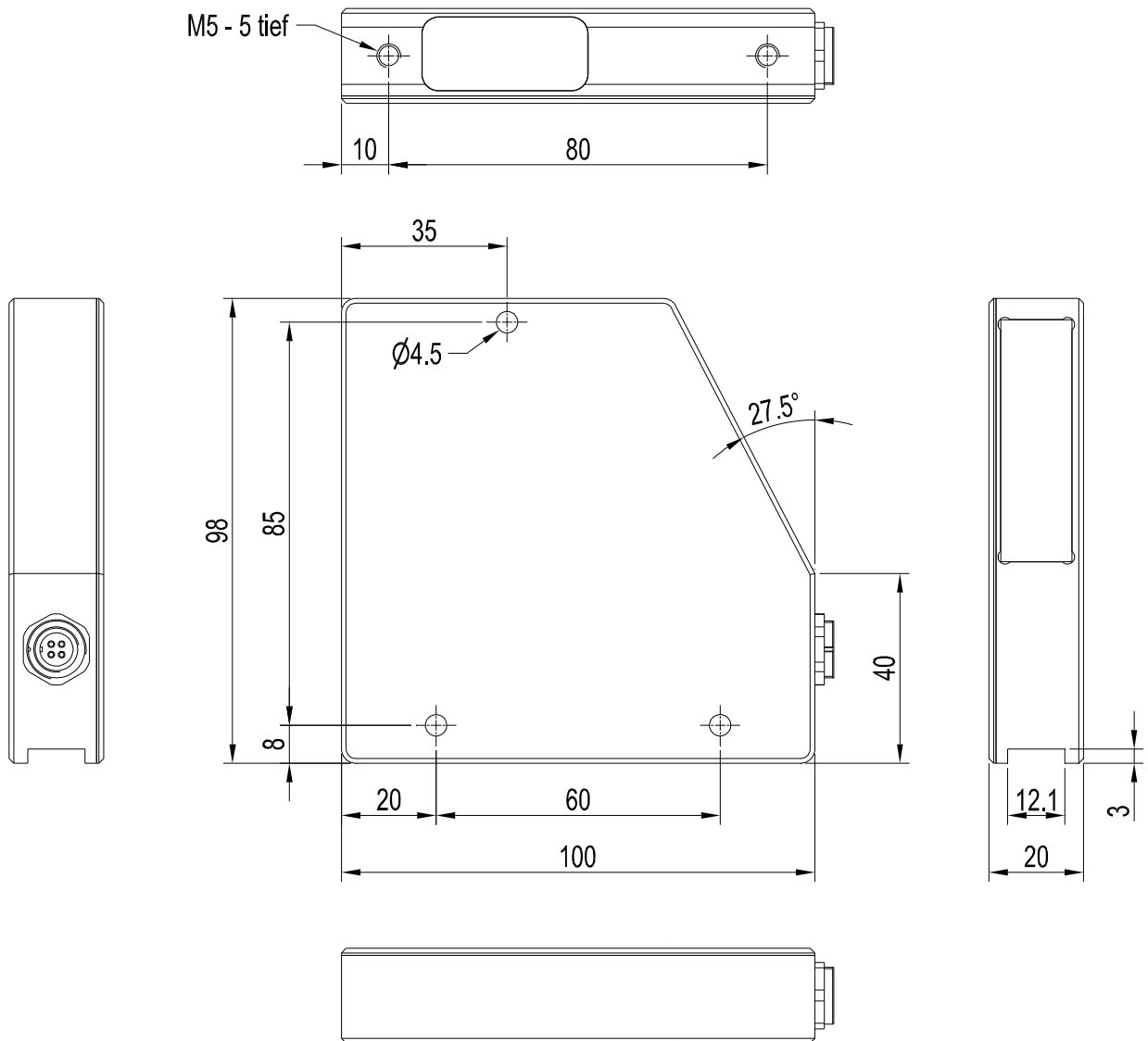

All dimensions in mm

Dimensions

**L-LAS-TB-28-R-AL**  
(Receiver)

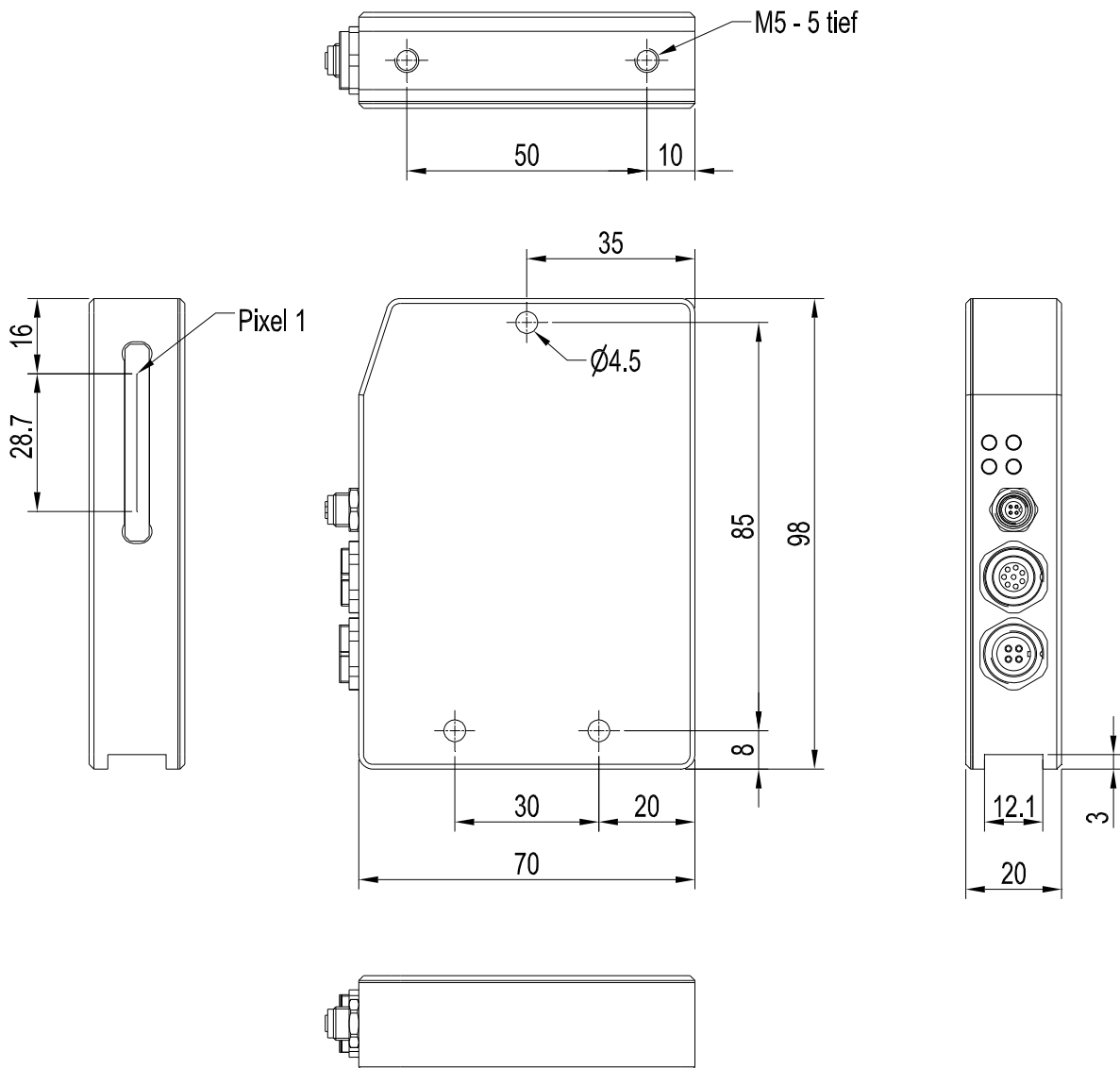

All dimensions in mm



**Connector Assignment**

**Connection L-LAS-TB-...-R-AL (Receiver) to PLC:  
8-pole fem. connector Binder Series 712**

Pin:	Color:	Assignment:
1	white	GND (0V)
2	brown	+24VDC (± 10%)
3	green	IN0 (EXT TRIGGER)
4	yellow	IN1 (TEACH / RESET)
5	grey	OUT0 (-)
6	pink	OUT1 (+)
7	blue	OUT2 (ok)
8	red	ANA (voltage 0...+10V or current 4...20mA)

Connecting cable:  
cab-las8/SPS-(length) or  
cab-las8/SPS-w-(length) (angle type 90°)  
(standard length 2m)

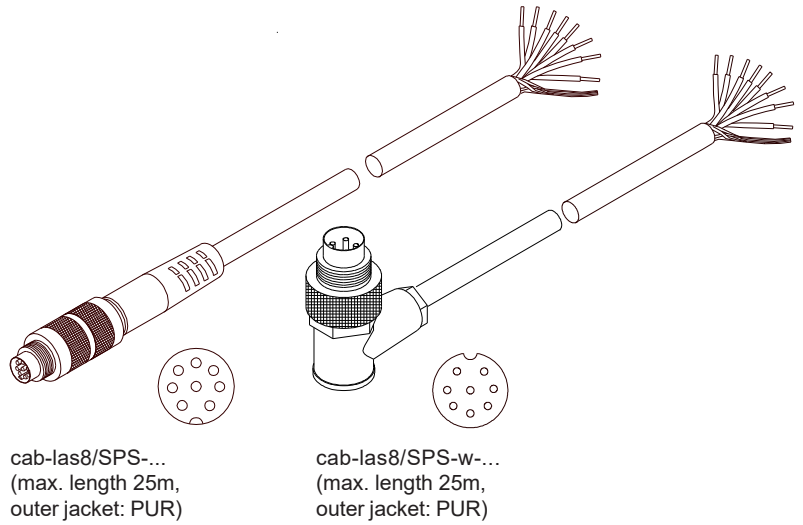

**Connection L-LAS-TB-...-R-AL (Receiver) to PC:  
4-pole fem. connector Binder Series 707**

Pin:	Assignment:
1	+24VDC (+Ub, OUT)
2	GND (0V)
3	RxD
4	TxD

**Connection via RS232 interface at the PC:**  
Connecting cable:  
cab-las4/PC-(length)  
cab-las4/PC-w-(length) (angle type 90°)  
(standard length 2m)

**alternative:**  
**Connection via USB interface at the PC:**  
USB converter (incl. driver software):  
cab-4/USB-(length)  
cab-4/USB-w-(length) (angle type 90°)  
(standard length 2m)

**alternative:**  
**Connection to local network via Ethernet bus:**  
Ethernet converter (incl. software „SensorFinder“):  
cab-4/ETH-500  
(standard length 0.5m)

Optional: External CAT5 cable, e.g.  
cab-eth/M12D-RJ45-flx-(length)

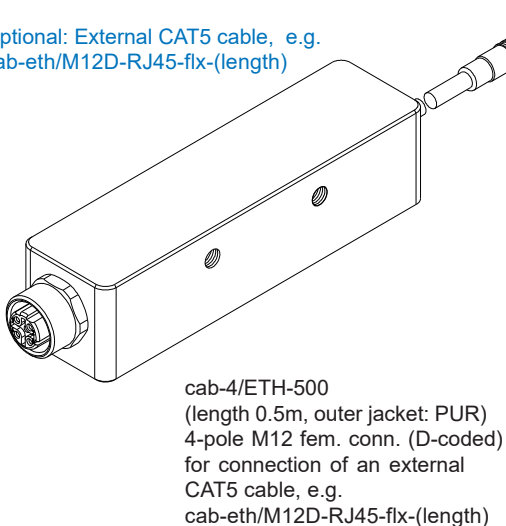
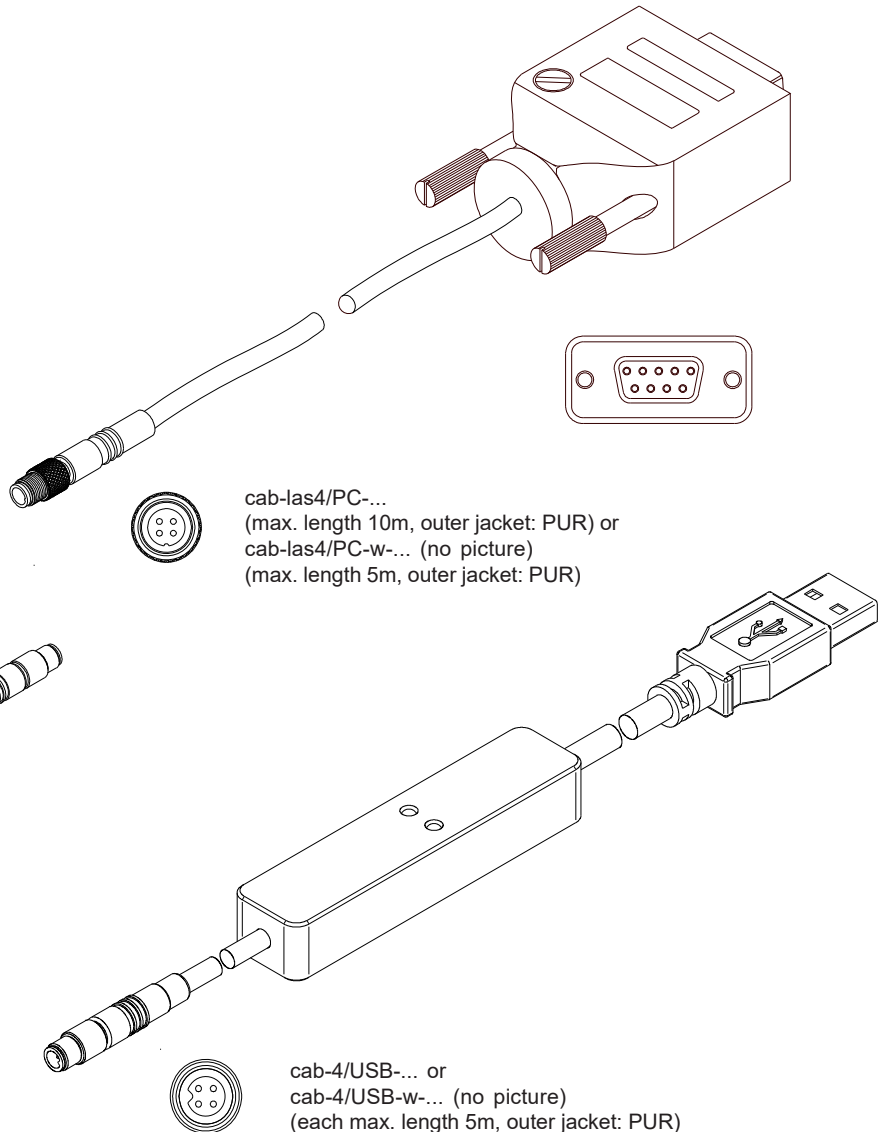

cab-4/ETH-500  
(length 0.5m, outer jacket: PUR)  
4-pole M12 fem. conn. (D-coded)  
for connection of an external  
CAT5 cable, e.g.  
cab-eth/M12D-RJ45-flx-(length)

Connector Assignment

Connection L-LAS-TB-...-T-AL (Transmitter)  
with L-LAS-TB-...-R-AL (Receiver)  
4-pole female connector Binder Series 712

Pin: Assignment:

- 1 +5VDC
- 2 0V (GND)
- 3 I-CONTROL (0V ... +5V)
- 4 not connected

Connecting cable:  
cab-las4-male-(length)  
cab-las4-male-w-(length) (angle type 90°)  
(standard length 2m)

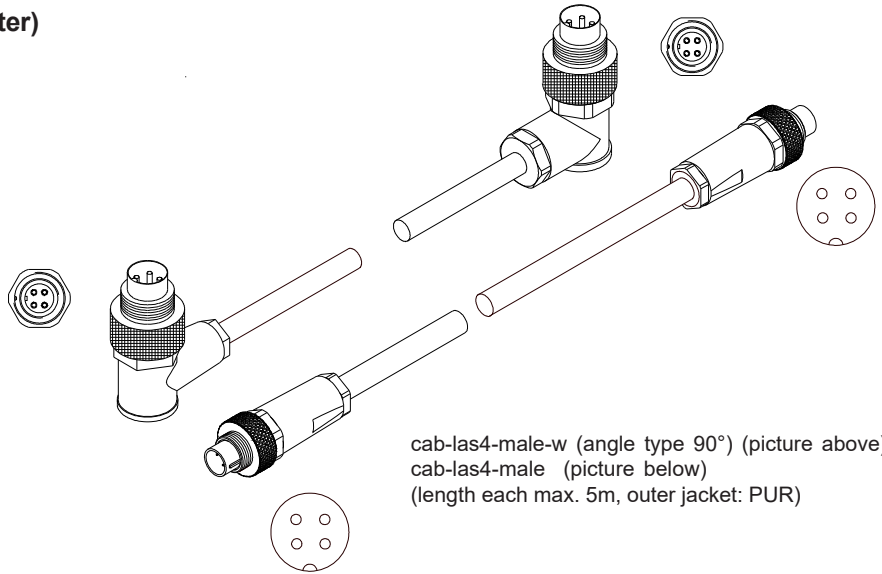

cab-las4-male-w (angle type 90°) (picture above) or  
cab-las4-male (picture below)  
(length each max. 5m, outer jacket: PUR)

LED Display

L-LAS-TB-28-R-AL  
(Receiver)

LED display:

- (+) ● Power
- (-) ● (ok)

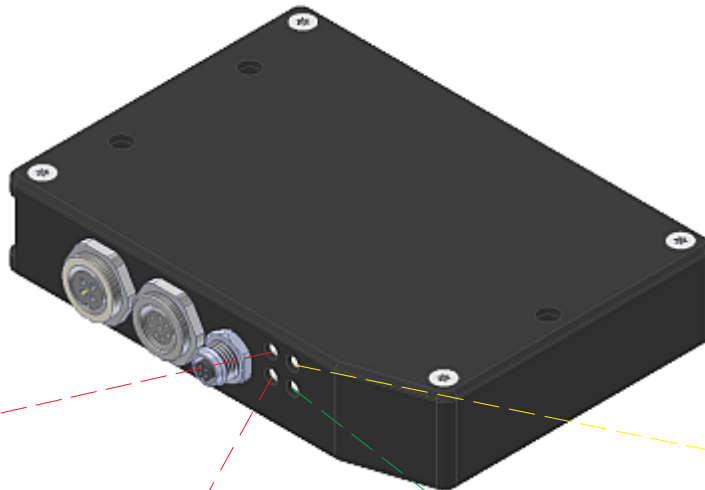

LED red (+): ●  
Measuring value  
> upper tolerance threshold  
(OUT1)

LED red (-): ●  
Measuring value  
< lower tolerance threshold  
(OUT0)

LED green (ok): ●  
Measuring value within  
tolerance window  
(OUT2)

LED yellow: ●  
Power LED  
(multifunctional)

Laser Information

The laser transmitters of L-LAS-TB series comply with laser class 1 according to EN 60825-1. Under reasonably foreseeable conditions a class 1 laser is safe. The reasonably foreseeable conditions are kept during specified normal operation. The use of these laser transmitters therefore requires no additional protective measures.

The laser transmitters of L-LAS-TB series series are supplied with an information label „CLASS 1 Laser Product“.



**Class 1 Laser Product**  
IEC 60825-1: 2014  
P<0.39 mW; λ=670 nm  
COMPLIES WITH 21 CFR 1040.10 AND 1040.11  
EXCEPT FOR CONFORMANCE WITH IEC 60825-1  
ED. 3, AS DESCRIBED IN  
LASER NOTICE NO. 56, DATED MAY 8, 2019.

**Parameterization**
**Windows® user interface:**

(The current software version is available for download on our website.)

The L-LAS-TB-...-AL sensor can be easily parameterised with the Windows® user interface L-LAS-TB-Scope (as of V5.0). For this purpose the sensor is connected to the PC with the serial interface cable cab-las4/PC (or cab-4/USB or cab-4/ETH). When parameterisation is finished, the PC can be disconnected again.

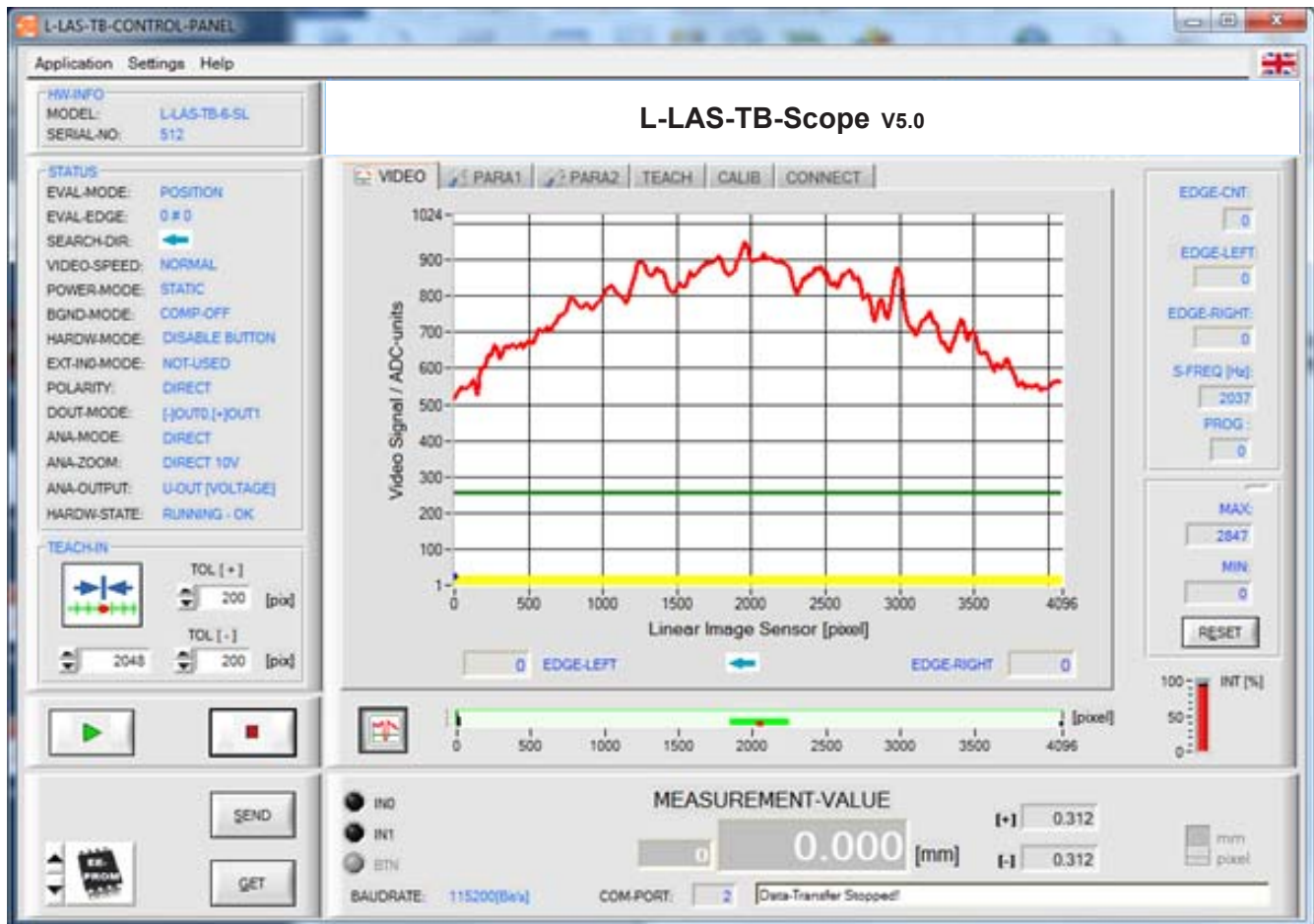
**Windows® user interface:**

With the help of the L-LAS-TB-Scope software the following settings can be made at the sensor:

- Setting of laser power and type of automatic power correction
- Polarity of digital outputs
- Different evaluation modes
- Start of the teach process by software button
- Setting of tolerance ranges for monitoring the measured value
- Selection of scan frequency

Furthermore, various numerical and graphical measured quantities can be visualized with the L-LAS-TB-Scope software. For example, the raw data of the CCD line sensor can be displayed graphically and numerically.



**Accessories**
**Mounting plate for L-LAS-TB-28-T-AL (Transmitter) and L-LAS-TB-28-R-AL (Receiver):**

(please order separately)

**TRA-L-LAS-TB-CL-L400** (total length 400 mm, max. transmitter/receiver distance cf. chart below)**TRA-L-LAS-TB-CL-L600** (total length 600 mm, max. transmitter/receiver distance cf. chart below)**TRA-L-LAS-TB-CL-L800** (total length 800 mm, max. transmitter/receiver distance cf. chart below)

(Aluminium housing, anodized in black)

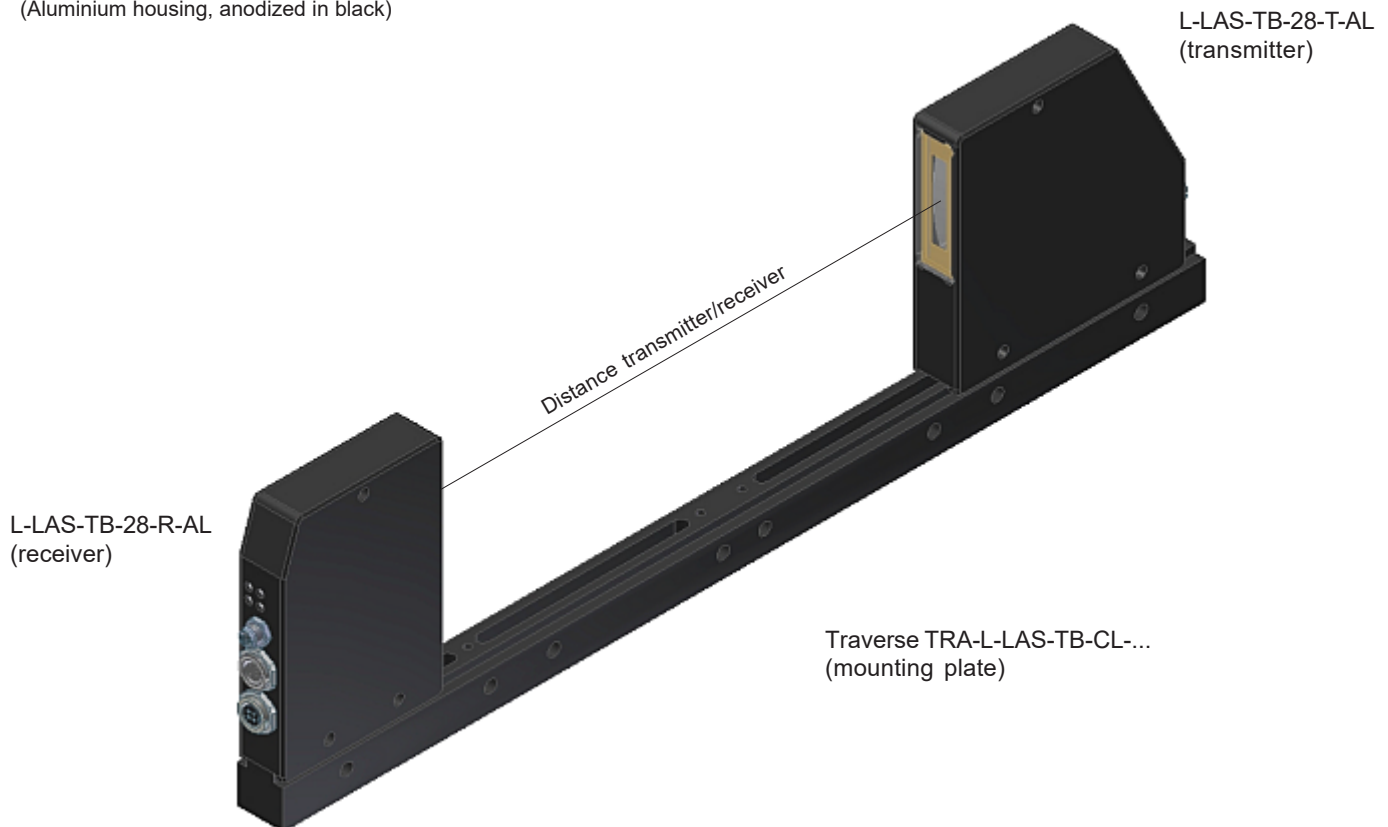

Max. distance T/R in case of use of mounting plate:	TRA-L-LAS-TB-CL- L200	TRA-L-LAS-TB-CL- L400	TRA-L-LAS-TB-CL- L600	TRA-L-LAS-TB-CL- L800
<b>L-LAS-TB-6-T-AL</b> <b>L-LAS-TB-6-R-AL</b>	max. distance T/R: 95 mm	max. distance T/R: 295 mm	max. distance T/R: 495 mm	max. distance T/R: 695 mm
<b>L-LAS-TB-(16)-T-AL</b> <b>L-LAS-TB-(16)-R-AL</b>	max. distance T/R: 60 mm	max. distance T/R: 260 mm	max. distance T/R: 460 mm	max. distance T/R: 660 mm
<b>L-LAS-TB-28-T-AL</b> <b>L-LAS-TB-28-R-AL</b>	----	max. distance T/R: 222 mm	max. distance T/R: 422 mm	max. distance T/R: 622 mm
<b>L-LAS-TB-50-T-AL</b> <b>L-LAS-TB-50-R-AL</b>	----	max. distance T/R: 205 mm	max. distance T/R: 405 mm	max. distance T/R: 605 mm
<b>L-LAS-TB-75-T-AL</b> <b>L-LAS-TB-75-R-AL</b>	----	max. distance T/R: 200 mm	max. distance T/R: 400 mm	max. distance T/R: 600 mm
<b>L-LAS-TB-100-T-AL</b> <b>L-LAS-TB-100-R-AL</b>	----	max. distance T/R: 160 mm	max. distance T/R: 360 mm	max. distance T/R: 560 mm





Accessories

**Blast air top part:**

**ABL-TB-28-CL**

(Plastic housing, black, please order separately for each transmitter and receiver)

**suitable for:**

**L-LAS-TB-28-T-AL** (Transmitter) **and**

**L-LAS-TB-28-R-AL** (Receiver)

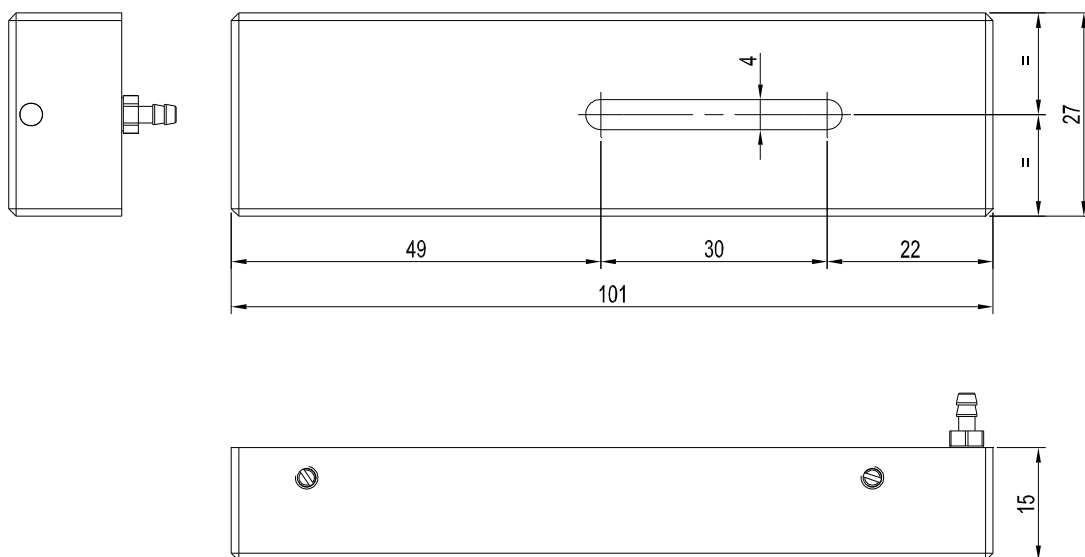
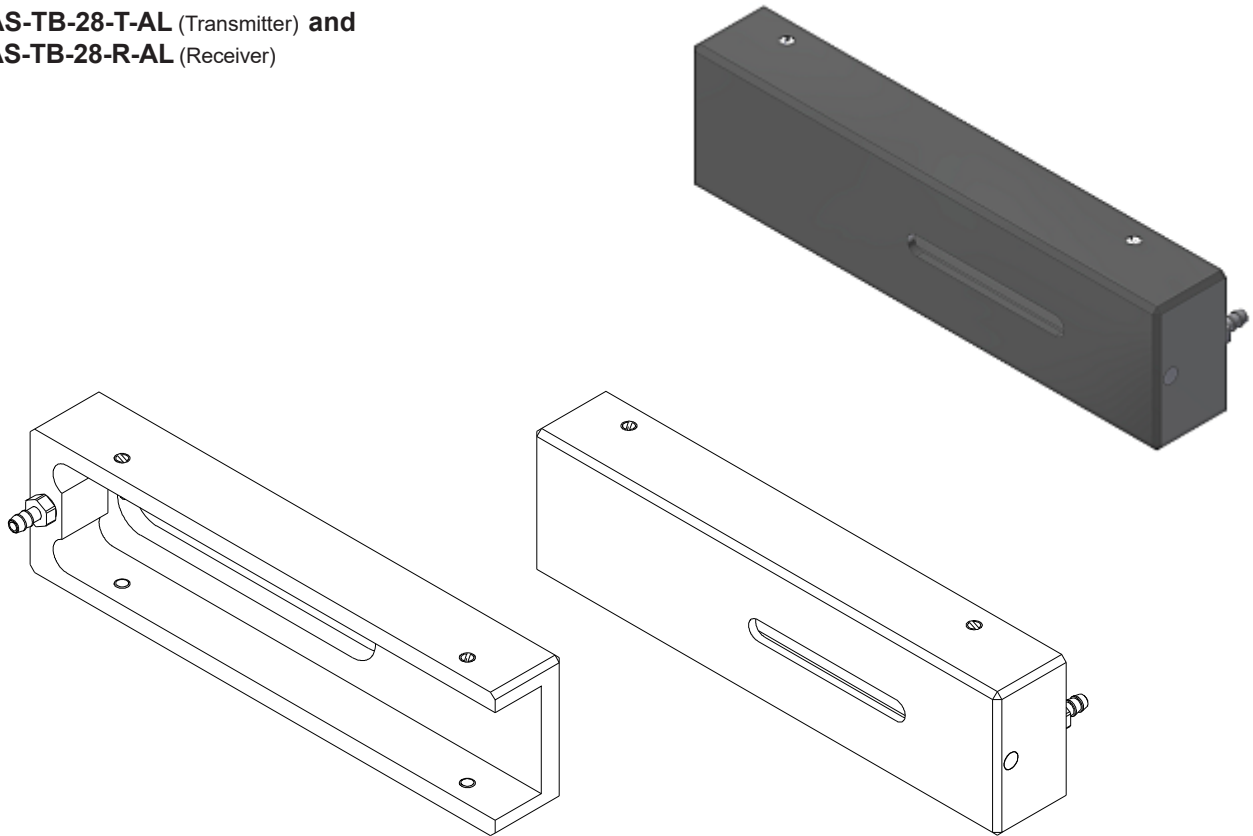

All dimensions in mm