

SPECTRO Series

► SPECTRO-3-500-COF-UV-d35.0-CL

- Measuring range typ. 100 mm ... 1000 mm
- Integrated transmitter and receiver optics (confocal)
- Up to 31 colors can be stored
- RS232 interface (USB or Ethernet adapter is available)
- 1x UV-LED, 385 nm, focussed (AC-, DC-, PULSE-operation or OFF for luminous objects can be switched)
- Detection of different luminescent colors
- Insensitive to outside light (in AC- or PULSE-operation)
- Brightness correction can be activated (STAT/DYN)
- Scan frequency max. 35 kHz (in DC- or OFF-operation)
- Switching frequency typ. 40 kHz
- Several TEACH functions (via PC, PLC, or push button)
- Various evaluation algorithms can be activated
- "BEST HIT" mode ("human color assessment")
- Switching state display by means of 5 yellow LEDs
- Parameterizable via Windows® software, scope function
- Temperature compensated
- Averaging can be activated (from 1 up to over 32000 values)
- Color control of luminous objects (LEDs, halogen lamps, displays, ...)
- 3-color filter detector (true color detector: "human color perception")



Design

Product name:

SPECTRO-3-500-COF-UV-d35.0-CL
(incl. Windows® software SPECTRO3-Scope
and SPECTRO3-COMFORT-Scope)

d35.0:
Spot size typ. Ø 40 mm at a distance of 500 mm

Accessories: (p. 10)

MOUNT-SPECTRO-3-JR/CL
(Mounting unit)

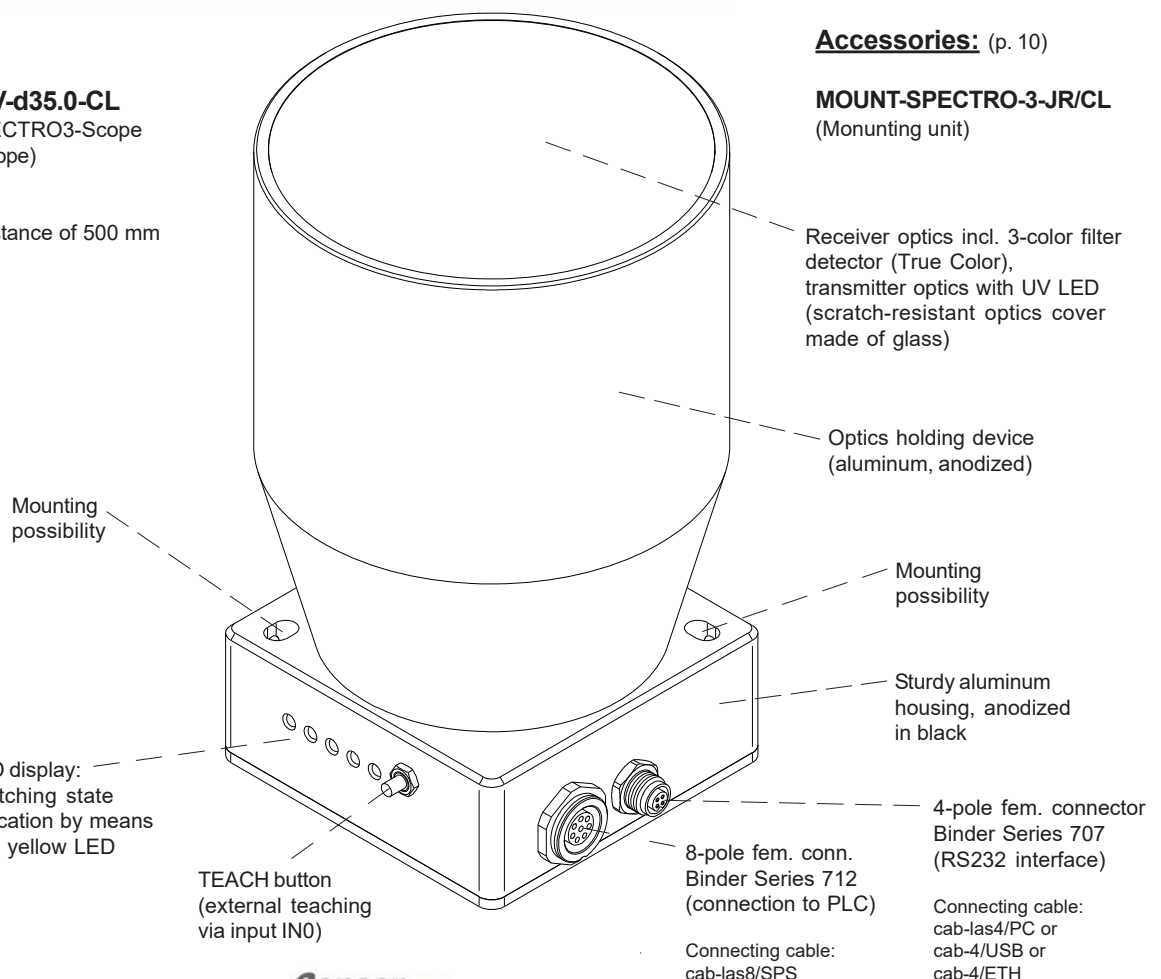

LED display:
Switching state
indication by means
of 5 yellow LED

TEACH button
(external teaching
via input IN0)

Receiver optics incl. 3-color filter
detector (True Color),
transmitter optics with UV LED
(scratch-resistant optics cover
made of glass)

Optics holding device
(aluminum, anodized)

Mounting
possibility

Sturdy aluminum
housing, anodized
in black

4-pole fem. connector
Binder Series 707
(RS232 interface)

8-pole fem. conn.
Binder Series 712
(connection to PLC)

Connecting cable:
cab-las8/SPS

Connecting cable:
cab-las4/PC or
cab-4/USB or
cab-4/ETH



Technical Data

| | |
|----------------------------|--|
| Model | SPECTRO-3-500-COF-UV-d35.0-CL |
| Voltage supply | +24VDC ($\pm 10\%$), reverse polarity protected, overcurrent protected |
| Current consumption | < 160 mA |
| Max. switching current | 100 mA, short circuit proof |
| Switching state indication | 5 yellow LED visualize the physical state of the outputs OUT0 ... OUT4 |
| Input digital (1x) | IN0 (Pin 3), digital (0V/+24V) or teach button at the housing |
| Outputs digital (5x) | OUT0 ... OUT4 (Pin 4 ... 8): digital (0V/+24V), npn-/pnp-able (bright-/dark-switching, can be switched) |
| Interface | RS232 |
| Pulse lengthening | 0 ... 100 ms, adjustable via PC software |
| Averaging | max. 32768 values, adjustable via PC software |
| Scan frequency | LED operation, can be switched via PC software: AC operation: max. 20 kHz (depends on parameterization) DC and OFF operation: max. 35 kHz (depends on parameterization) PULSE operation: max. 5 kHz (depends on parameterization) |
| Switching frequency | typ. 40 kHz |
| Transmitter (light source) | UV-LED, 385 nm |
| Transmitter control | can be switched via PC software: AC operation (LED MODE-AC), DC operation (LED MODE-DC), OFF operation (LED MODE-OFF) |
| Measuring range | typ. 100 mm ... 1000 mm |
| Receiver | 3-color filter detector (TRUE COLOR detector, "human color perception"), color filter curves acc. to CIE 1931 |
| Receiver gain setting | 8 steps (AMP1 ... AMP8), adjustable via PC software |
| Ambient light | max. 5000 Lux |
| Size of light spot | typ. \varnothing 5 mm at distance 100 mm typ. \varnothing 23 mm at distance 300 mm typ. \varnothing 40 mm at distance 500 mm typ. \varnothing 59 mm at distance 700 mm typ. \varnothing 73 mm at distance 900 mm |
| Reproducibility | in the X, Y color range each 1 digit at 12-bit A/D conversion |
| Temperature drift X,Y | $\Delta X/\Delta T$; $\Delta Y/\Delta T$ typ. 0,2 digits/ $^{\circ}\text{C}$ (< 0,01% / $^{\circ}\text{C}$) |
| Color difference | $\Delta E \geq 0,5$ |
| Color space | X Y INT siM (Lab) |
| Color memory capacity | non-volatile EEPROM with parameter sets for max. 31 colors |
| Housing dimensions | LxWxH approx. 65 mm x 65 mm x 124 mm (incl. optics holding device \varnothing 80 mm, without flange connectors) |
| Housing material | aluminum, anodized in black (optics holding device: aluminum, anodized) |
| Enclosure rating | IP67 (optics), IP64 (electronics) |
| Connecting cables | to PLC: cab-las8/SPS or cab-las8/SPS-w to PC/RS232 interface: cab-las4/PC or cab-las4/PC-w to PC/USB interface: cab-4/USB or cab-4/USB-w to PC/Ethernet interface: cab-4/ETH |
| Type of connector | connection to PLC: 8-pole fem. connector (Binder 712), connection to PC: 4-pole fem. connector (Binder 707) |
| Operating temp. range | -20 $^{\circ}\text{C}$... +55 $^{\circ}\text{C}$ |
| Storage temp. range | -20 $^{\circ}\text{C}$... +85 $^{\circ}\text{C}$ |
| EMC test acc. to | DIN EN 60947-5-2 |

Dimensions

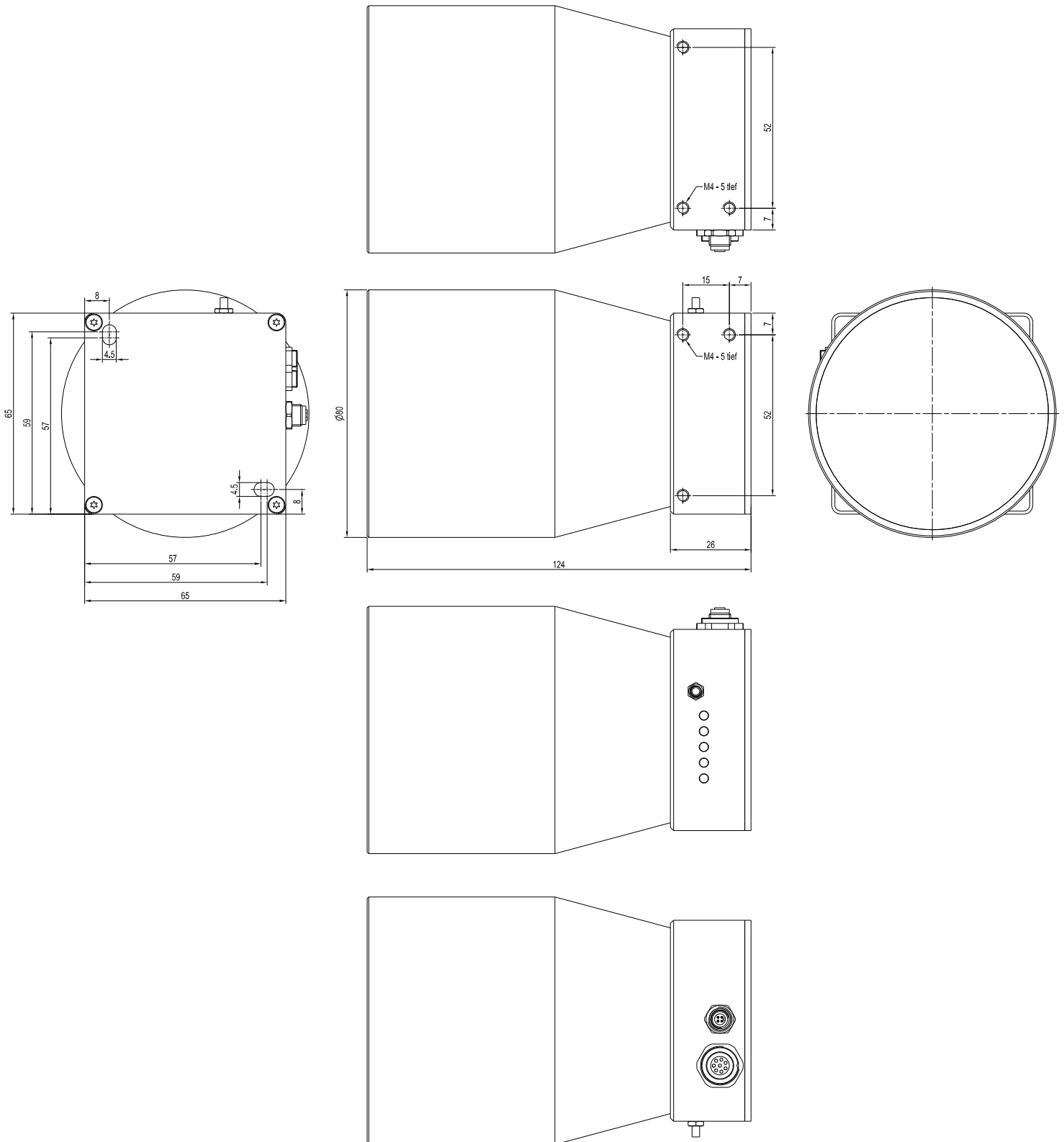

All dimensions in mm



Connector Assignment
Connection to PLC:**8-pole fem. connector Binder Series 712**

| Pin: | Color: | Assignment: |
|------|---------------|--|
| 1 | white | GND (0V) |
| 2 | brown | +24VDC ($\pm 10\%$) |
| 3 | green | IN0 |
| 4 | yellow | OUT0 (Digital 0: typ. 0...1V, Digital 1: typ. +Ub - 10%) |
| 5 | grey | OUT1 (Digital 0: typ. 0...1V, Digital 1: typ. +Ub - 10%) |
| 6 | pink or black | OUT2 (Digital 0: typ. 0...1V, Digital 1: typ. +Ub - 10%) |
| 7 | blue | OUT3 (Digital 0: typ. 0...1V, Digital 1: typ. +Ub - 10%) |
| 8 | red | OUT4 (Digital 0: typ. 0...1V, Digital 1: typ. +Ub - 10%) |

Connecting cable:

cab-las8/SPS-(length)

cab-las8/SPS-w-(length) (angle type, 90°)

(standard length 2m)

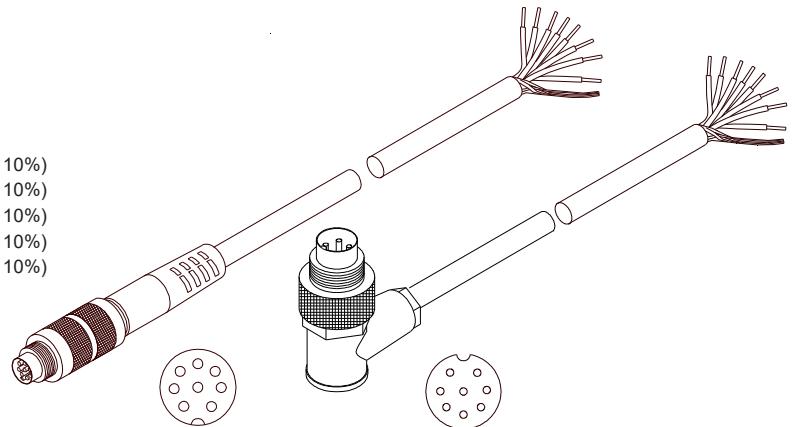
cab-las8/SPS-...
(max. length 25m, outer jacket: PUR)cab-las8/SPS-w-...
(max. length 25m, outer jacket: PUR)**Connection to PC:****4-pole fem. connector Binder Series 707**

| Pin: | Assignment: |
|------|-------------------|
| 1 | +24VDC (+Ub, OUT) |
| 2 | GND (0V) |
| 3 | RxD |
| 4 | TxD |

Connection via RS232 interface at the PC:**Connecting cable:**

cab-las4/PC-(length)

cab-las4/PC-w-(length) (angle type 90°)

(standard length 2m)

alternative:**Connection via USB interface at the PC:**

Connecting cable (incl. driver software):

cab-4/USB-(length)

cab-4/USB-w-(length) (angle type 90°)

(standard length 2m)

alternative:**Connection to local network via Ethernet bus:**

Adapter (incl. software „SensorFinder“):

cab-4/ETH-500

(standard length 0.5m)

Optional: External CAT5 cable, e.g.

cab-eth/M12D-RJ45-flx-(length)

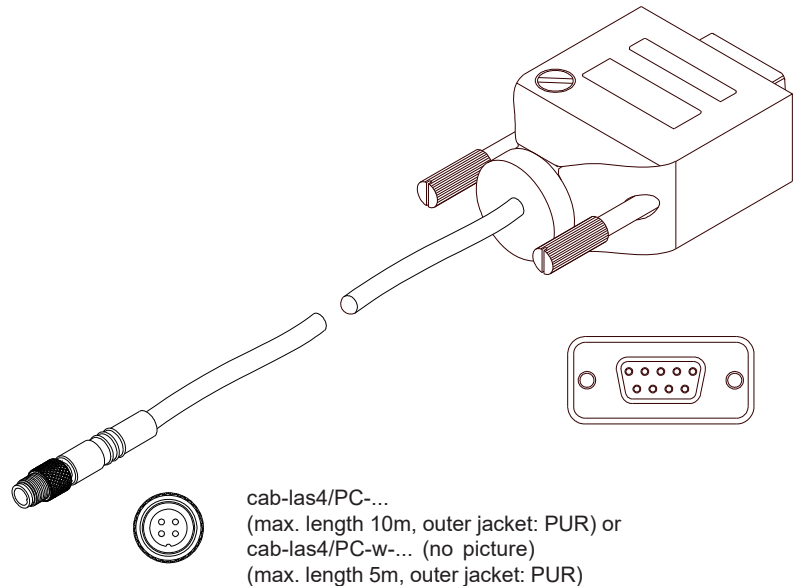
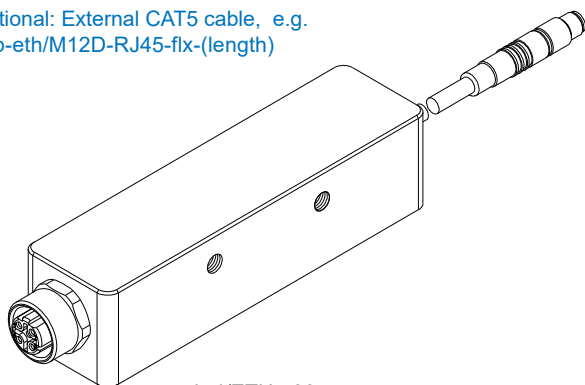
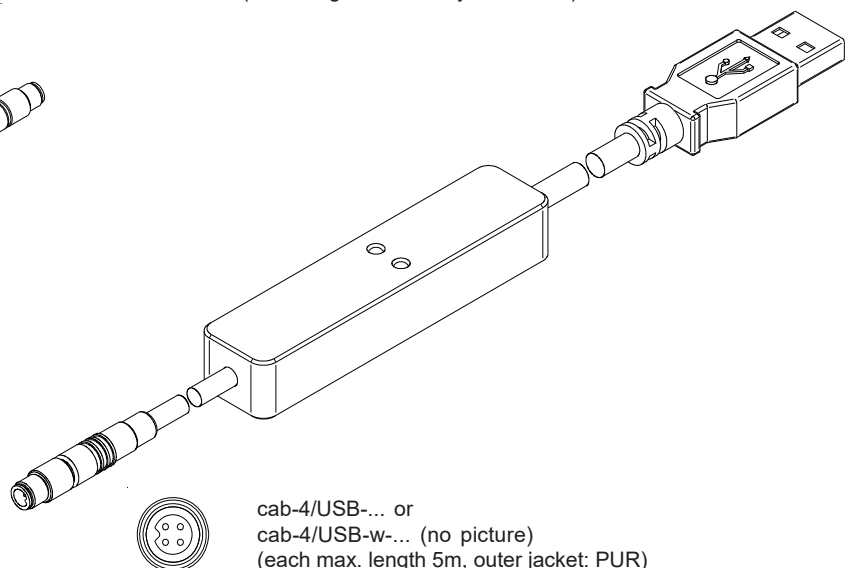
cab-las4/PC-...
(max. length 10m, outer jacket: PUR) or
cab-las4/PC-w-... (no picture)
(max. length 5m, outer jacket: PUR)cab-4/ETH-500
(length 0.5m, outer jacket: PUR)
4-pole M12 fem. conn. (D-coded)
for connection of an external
CAT5 cable, e.g.
cab-eth/M12D-RJ45-flx-(length)cab-4/USB-... or
cab-4/USB-w-... (no picture)
(each max. length 5m, outer jacket: PUR)



Measuring Principle

Measuring principle of color sensors of SPECTRO-3-...-UV series:

The SPECTRO-3 provides highly flexible signal acquisition. For example, the sensor can be operated in alternating-light mode (AC mode), which makes the sensor insensitive to extraneous light. It also can be set to constant-light mode (DC mode), which makes the sensor extremely fast and allows a scan-frequency of up to 35 kHz.

When the integrated light source of the SPECTRO-3-...-UV color sensor is activated, the sensor detects the radiation that is diffusely reflected from the object to be measured.

As a light source the SPECTRO-3-...-UV color sensor uses a UV-LED (375 nm, or 365 nm in case of using an external UV illumination unit SPECTRO-ELS-UV) with adjustable transmitter power to excite the luminescent marking. An integrated 3-fold receiver for the red, green, and blue content of the visible light that is emitted by the luminescent marking is used as a receiver. A special feature here is that the gain of the receiver can be set in 8 steps. This makes it possible to optimally adjust the sensor to almost any luminescent colorant that can be excited in the long-wave UV range (375 nm or 365 nm).

The SPECTRO-3 color sensor can be "taught" up to 31 colors. For each of these taught colors it is possible to set tolerances. In X/Y INT or s/i M mode these tolerances form a color cylinder in space. In X/Y/INT or s/i/M mode the tolerances form a color sphere in space. Color evaluation according to s/i M is based on the lab calculation method. All modes can be used in combination with several operating modes such as "FIRST HIT" and "BEST HIT". Raw data are represented with 12 bit resolution.

As a special feature the sensor can be taught two completely independent parameter sets. Input IN0 can then be used to tell the sensor which parameter set it should work with.

Color detection either operates continuously or is started through an external PLC trigger signal. The respective detected color either is provided as a binary code at the 5 digital outputs or can be sent directly to the outputs, if only up to 5 colors are to be detected. At the same time the detected color code is visualised by means of 5 LEDs at the housing of the SPECTRO-3. [Please note: Visualisation by means of LEDs not available with SPECTRO-3-...-JR types.]

With a TEACH button at the sensor housing the color sensor can be taught up to 31 colors. For this purpose the corresponding evaluation mode must be set with the software. The TEACH button is connected in parallel to the input IN0 (green wire at cable cab-las8/SPS). [Please note: TEACH button not available with SPECTRO-3-...-JR types.]

Parameters and measurement values can be exchanged between a PC and the SPECTRO-3 color sensor through the serial RS232 interface. All the parameters for color detection also can be saved to the non-volatile EEPROM of the SPECTRO-3 color sensor through this serial RS232 interface. When parameterisation is finished, the color sensor continues to operate with the current parameters in STAND-ALONE mode without a PC.

The sensors of the SPECTRO-3-...-UV series also can be calibrated. Analogous to white-light balancing with color sensors, balancing of the SPECTRO-3-...-UV could be performed to any luminescent color marking.



Visualization

Visualization of the color code:

The color code is visualised by way of 5 yellow LEDs at the housing of the SPECTRO-3 color sensor. At the same time in the binary mode (OUT BINARY) the color code indicated on the LED display is output as 5-bit binary information at the digital outputs OUT0 to OUT4 of the 8-pin SPECTRO-3/PLC socket.

The SPECTRO-3 color sensor is able to process a maximum of 31 colors (color code 0 ... 30) in accordance with the corresponding rows in the COLOR TEACH TABLE. An "error" respectively a "not detected color" is displayed by the lighting of all LED (OUT0 ... OUT4 digital outputs are set to HIGH-level).

In the DIRECT mode (OUT DIRECT HI or OUT DIRECT LO) the maximum numbers of colors to be taught is 5 (color no. 0, 1, 2, 3, 4). If DIRECT HI is activated, the specially digital output is set to HI, while the other 4 are set to LO. If the current color does not correspond with any of the teach-in colors, all digital outputs are set to LOW (no LED is lighting).

If DIRECT LO is activated, the specially digital output is set to LO, while the other 4 are set to HI. If the current color does not correspond with any of the teach-in colors, all digital outputs are set to HIGH (all LED are lighting).



LED Display

LED display:

The color code is visualized by means of 5 yellow LEDs at the housing of the color sensor. At the same time the color code indicated at the LED display is output as 5-bit binary information at the digital outputs OUT0 ... OUT4 of the 8-pole PLC connector.

In the DIRECT mode the maximum number of color codes to be taught is 5. These 5 color codes can be directly output at the 5 digital outputs. The respective detected color code is displayed by means of the 5 yellow LEDs at the color sensor housing.

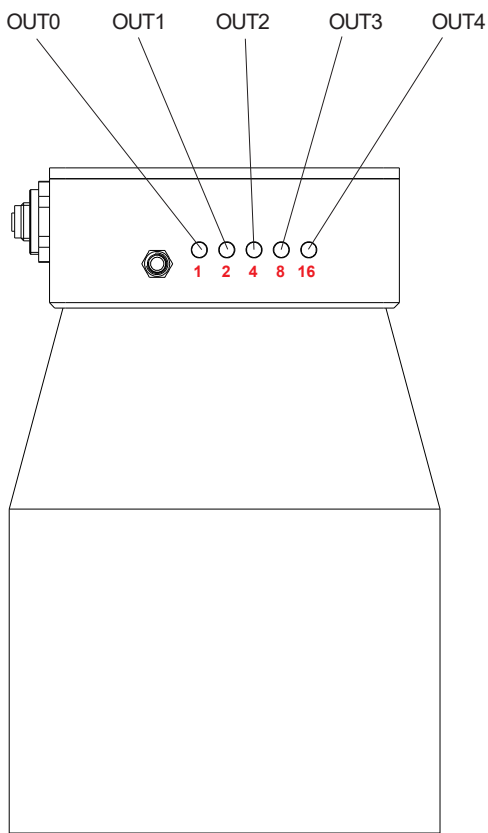

| | | |
|-----------|----------------------------|-----------|
| ○ ○ ○ ○ ○ | ● ○ ○ ○ ○ | ○ ● ○ ○ ○ |
| 0 | 1 | 2 |
| ● ● ○ ○ ○ | ○ ○ ● ○ ○ | ● ○ ● ○ ○ |
| 3 | 4 | 5 |
| ○ ● ● ○ ○ | ● ● ● ○ ○ | ○ ○ ○ ● ○ |
| 6 | 7 | 8 |
| ● ○ ○ ● ○ | ○ ● ○ ● ○ | ● ● ○ ● ○ |
| 9 | 10 | 11 |
| ○ ○ ● ● ○ | ● ○ ● ● ○ | ○ ● ● ● ○ |
| 12 | 13 | 14 |
| ● ● ● ● ○ | ○ ○ ○ ○ ● | ● ○ ○ ○ ● |
| 15 | 16 | 17 |
| ○ ● ○ ○ ● | ● ● ○ ○ ● | ○ ○ ● ○ ● |
| 18 | 19 | 20 |
| ● ○ ● ○ ● | ○ ● ● ○ ● | ● ● ● ○ ● |
| 21 | 22 | 23 |
| ○ ○ ○ ● ● | ● ○ ○ ● ● | ○ ● ○ ● ● |
| 24 | 25 | 26 |
| ● ● ○ ● ● | ○ ○ ● ● ● | ● ○ ● ● ● |
| 27 | 28 | 29 |
| ○ ● ● ● ● | ● ● ● ● ● | |
| 30 | Error or „not detected“ | |

Windows® user interface:

(The current software version is available for download on our website.)

The color sensor is parameterized under Windows® with the SPECTRO3-Scope software. The Windows® user interface facilitates the teach-in process at the color sensor and supports the operator in the task of adjustment and commissioning of the color sensor.

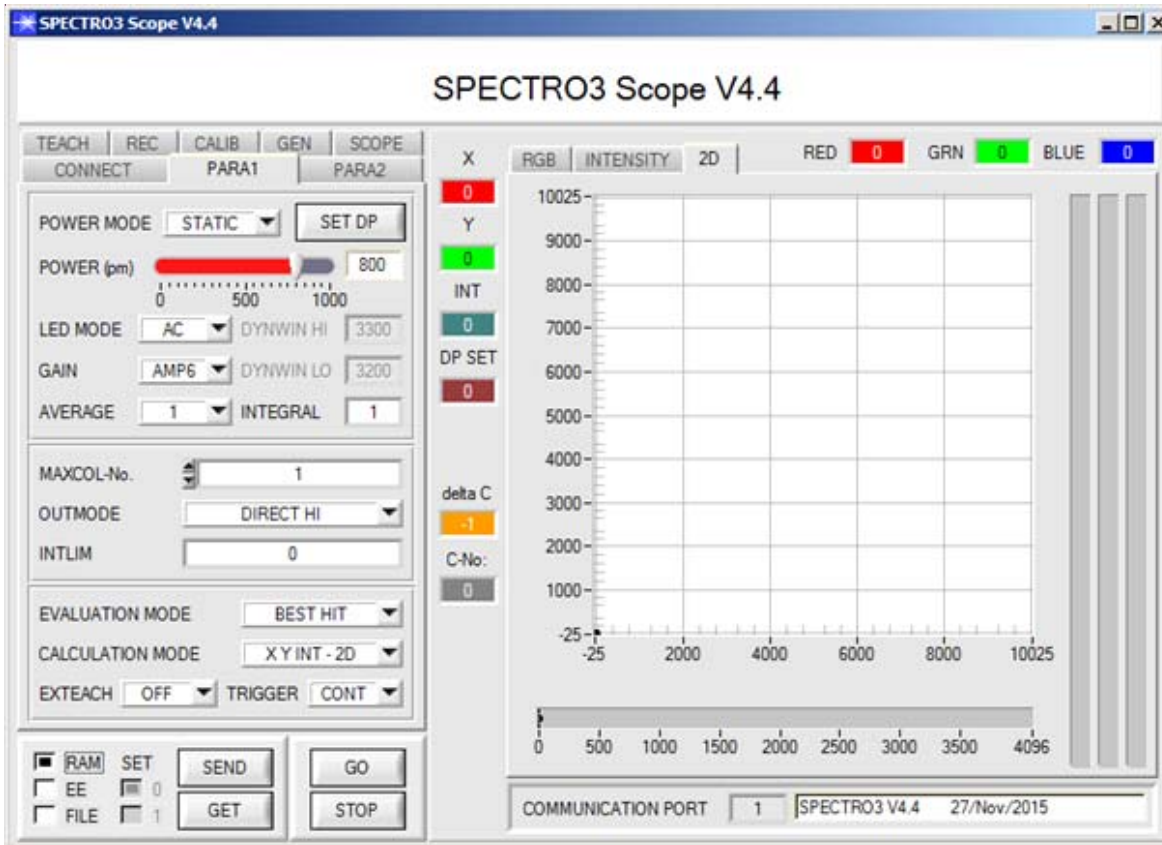

Under Windows® representation of the color value on a PC in numeric form and in a color chart, and representation of RGB values in a time chart. In addition the current RGB values are displayed as a bar chart.

The RS232 interface (tab PARA1 or PARA2) is used for setting parameters such as:

- POWER MODE: Light power of the LED
- SET DP: Set Double Parameter
- LED MODE: Triggering of the internal light source
- GAIN: Used for setting the gain of the receiver
- AVERAGE: Averaging over a maximum of 32768 values
- INTEGRAL: This function field is used to set the number of scan values (measurement values) over which the raw signal measured at the receiver is summed up. This integral function allows the reliable detection even of extremely weak signals
- MAXCOL-No.: Number of colors to be checked
- OUTMODE: Triggering of the digital outputs
- INTLIM: Minimum intensity required for color evaluation
- EVALUATION MODE: Various evaluation modes to choose from (FIRST HIT, BEST HIT, MIN DIST, COL5, THD RGB)
- CALCULATION MODE: There are 2 methods of teaching a color, which are selectable via CALCULATION MODE. The CALCULATION MODE „X Y INT - 3D“ (or „s i M - 3D“) uses a color sphere in space with radius TOL. Contrary to this, the CALCULATION MODE „X Y INT - 2D“ (or „s i M - 2D“) uses a color cylinder in space with radius CTO or siTO and with height ITO or M. The teach process is the same for both methods. Color evaluation according to „s i M - 2D“ uses the Lab calculation method
- EXTEACH: In all the evaluation modes teaching of a color can be performed externally through IN0 or by means of the button at the sensor housing [Please note: TEACH button not available with SPECTRO-3-...-JR types.]
- TRIGGER: Continuous or external or self trigger

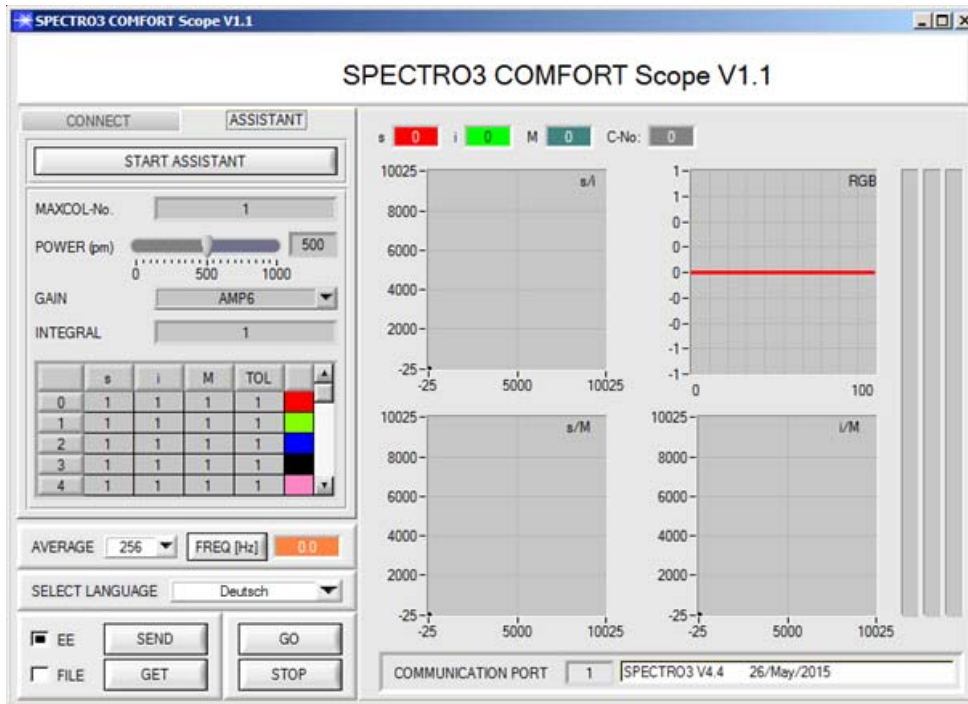

Parametrization
Windows® user interface SPECTRO3-COMFORT-Scope as an alternative to SPECTRO3-Scope:

Color sensors of the following types can be quickly parameterised with the SPECTRO3-COMFORT-SCOPE software:

SPECTRO-3 (im M34 housing)
 SPECTRO-3-CL
 SPECTRO-3-JR
 SPECTRO-3-SL
 SPECTRO-3-SLE

The software features menu guidance that prompts the user to enter all the relevant parameters.

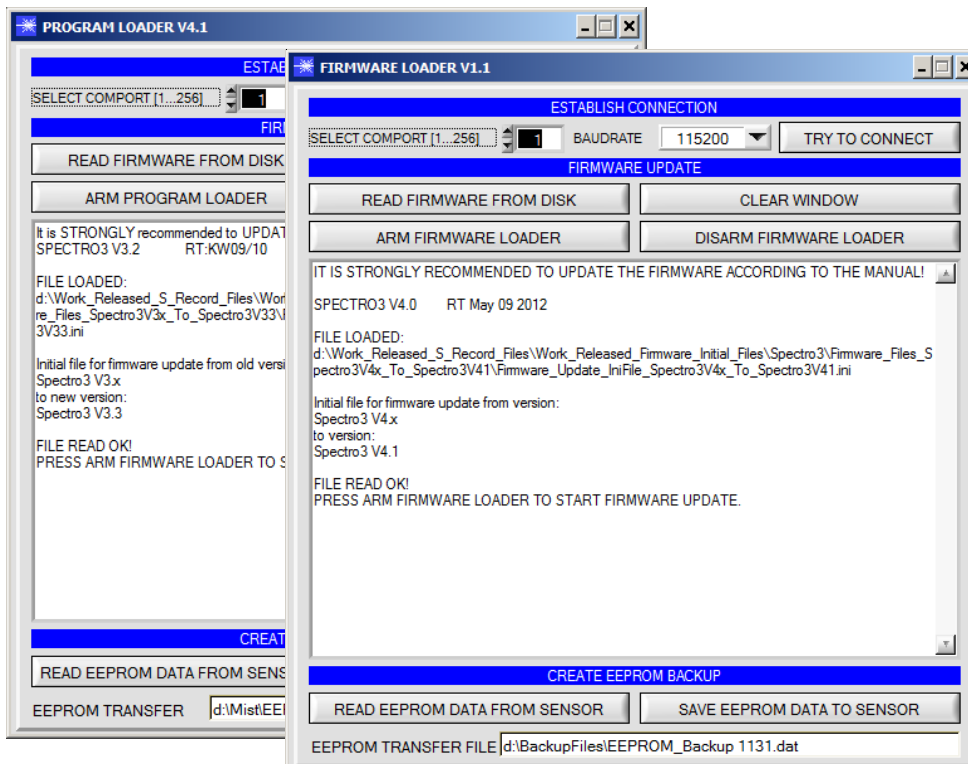

Firmware Update
Firmware update by means of software „ProgramLoader“ or „FirmwareLoader“:

The software „ProgramLoader“ or „FirmwareLoader“ allows the user to perform an automatic firmware update. The update will be carried out through the RS232 interface.

An initialisation file (xxx.ini) and a firmware file (xxx.elf.S) are required for performing a firmware update. These files can be obtained from your supplier. In some cases an additional firmware file for the program memory (xxx.elf.p.S) is also needed, and this file will be automatically provided together with the other two files.



Diagrams

Diagrams: SPOT DIAMETER and RELATIVE INTENSITY
SPECTRO-3-500-COF-UV-d35.0-CL

Spot diameter

SPECTRO-3-500-COF-UV-d35.0-CL:
40 mm (typ.) at a working distance of 500 mm

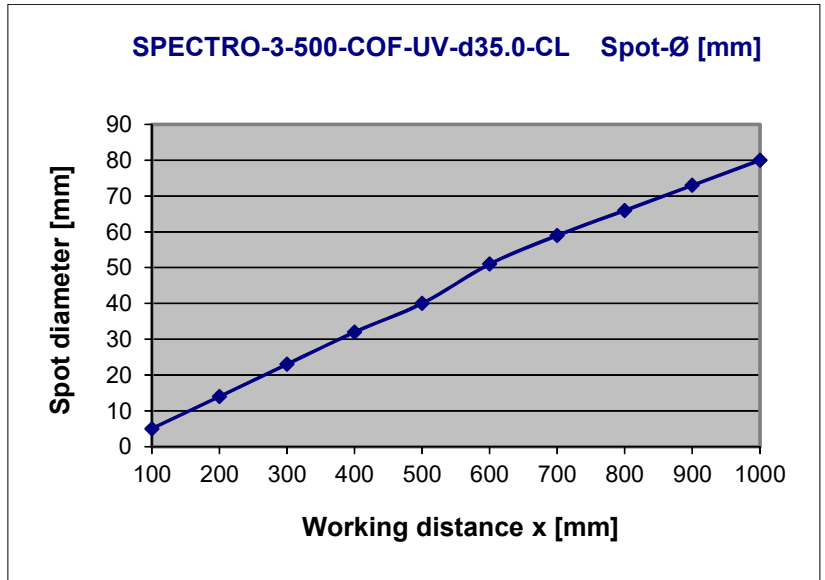



Accessories

Mounting unit
MOUNT-SPECTRO-3-JR/CL
 (please order separately)

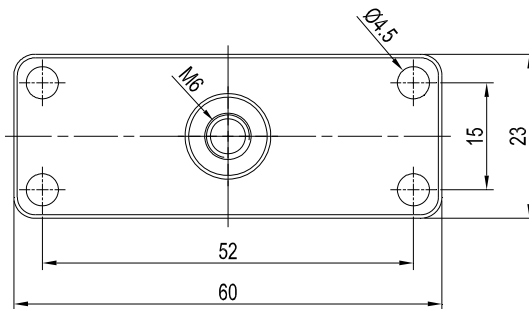
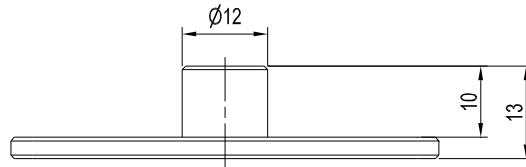
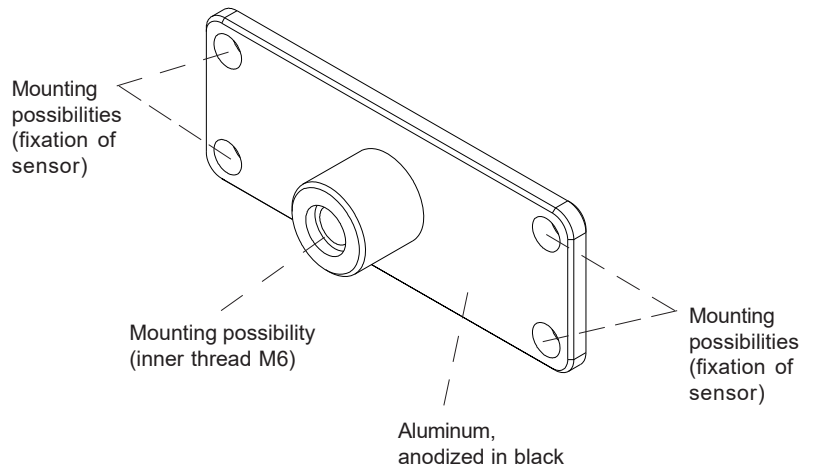

(All dimensions in mm)

Example of use:

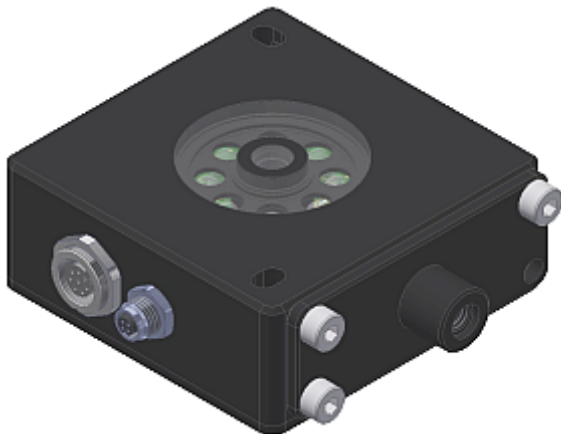

Example:
 MOUNT-SPECTRO-3-JR/CL mounting unit
 mounted on SPECTRO-3-50-FCL-JR color sensor