

SPECTRO Series

► SPECTRO-3-DIL-SL

- Object distance typ. 5 mm ... 50 mm
- Integrated transmitter and receiver optics
- Reduction of gloss effect due to diffuse illumination
- Up to 3 colors (max. 64 colors in GROUP mode) can be taught
- RS232 interface (USB or Ethernet converter is available)
- Super-bright white-light LED, diffuse (AC-/DC-operation or OFF for luminous objects can be switched)
- Color detection, contrast detection, and gray scale detection
- Insensitive to outside light (in AC-operation)
- Brightness correction can be activated (STAT/DYN)
- Scan frequency max. 85 kHz (in DC- or OFF-operation)
- Switching frequency typ. 60 kHz
- TEACH via PC or teach button
- Various evaluation algorithms can be activated
- "BEST HIT" mode ("human color assessment")
- Switching state indication by means of 2 yellow LED
- Parameterizable via Windows® software, scope function
- Temperature compensated
- Averaging can be activated (from 1 up to over 32000 values)
- Color control of luminous objects (LEDs, halogen lamps, displays, ...)
- 3-color filter detector (true color detector: "human color perception")
- Compact aluminum housing

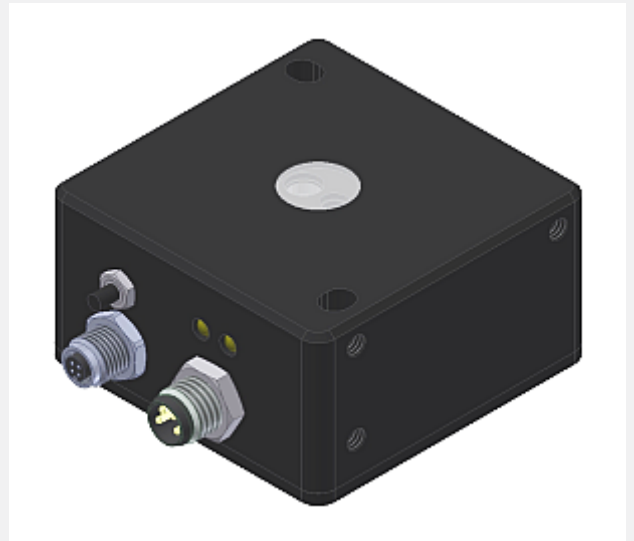

Design

Product name:

SPECTRO-3-DIL-SL

(incl. Windows® PC software
SPECTRO3-SL-Scope and
SPECTRO3-COMFORT-Scope)

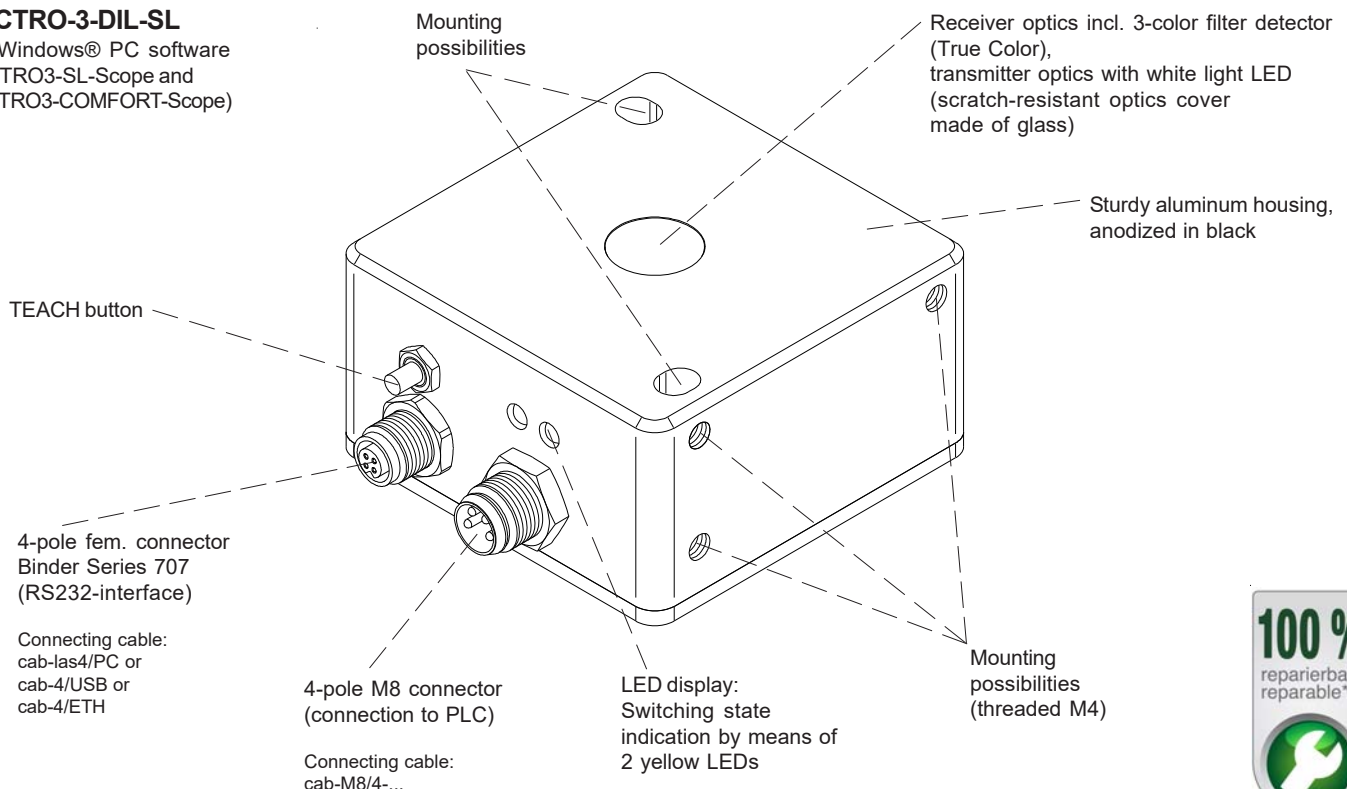



Technical Data

Model	SPECTRO-3-DIL-SL						
Voltage supply	+24VDC ($\pm 10\%$), reverse polarity protected, overcurrent protected						
Current consumption	< 160 mA						
Max. switching current	100 mA, short circuit proof						
Switching state indication	2 yellow LED visualize the physical state of the outputs OUT0 and OUT1						
Outputs digital (2x)	OUT0 and OUT1 (Pin 2 and Pin 4): digital (0V/+24V), npn-/pnp-able (bright-/dark-switching, can be switched)						
Interface	RS232						
Pulse lengthening	0 ... 100 ms, adjustable via PC software						
Averaging	max. 32768 values, adjustable via PC software						
Scan frequency	LED operation, can be switched via PC software: AC operation: max. 28 kHz (depends on parameterization) DC and OFF operation: max. 85 kHz (depends on parameterization)						
Switching frequency	typ. 60 kHz						
Transmitter (light source)	super-bright white-light LED, diffuse						
Transmitter control	can be switched via PC software: AC operation (LED MODE-AC), DC operation (LED MODE-DC), OFF operation (LED MODE-OFF)						
Measuring range	typ. 5 mm ... 50 mm						
Receiver	3-color filter detector (TRUE COLOR detector, "human color perception"), color filter curves acc. to CIE 1931						
Receiver gain setting	8 steps (AMP1 ... AMP8), adjustable via PC software						
Ambient light	max. 5000 Lux						
Detection range (half intensity width)	<table style="width: 100%; border: none;"> <tr> <td style="width: 50%;">typ. 5 mm at a distance of 5 mm</td> <td style="width: 50%;">typ. 16 mm at a distance of 30 mm</td> </tr> <tr> <td>typ. 8 mm at a distance of 10 mm</td> <td>typ. 23 mm at a distance of 40 mm</td> </tr> <tr> <td>typ. 12 mm at a distance of 20 mm</td> <td>typ. 29 mm at a distance of 50 mm</td> </tr> </table>	typ. 5 mm at a distance of 5 mm	typ. 16 mm at a distance of 30 mm	typ. 8 mm at a distance of 10 mm	typ. 23 mm at a distance of 40 mm	typ. 12 mm at a distance of 20 mm	typ. 29 mm at a distance of 50 mm
typ. 5 mm at a distance of 5 mm	typ. 16 mm at a distance of 30 mm						
typ. 8 mm at a distance of 10 mm	typ. 23 mm at a distance of 40 mm						
typ. 12 mm at a distance of 20 mm	typ. 29 mm at a distance of 50 mm						
Reproducibility	in the X, Y color range each 1 digit at 12-bit A/D conversion						
Temperature drift X,Y	$\Delta X/\Delta T$; $\Delta Y/\Delta T$ typ. 0,2 digits/ $^{\circ}\text{C}$ (< 0,01% / $^{\circ}\text{C}$)						
Color difference	$\Delta E \geq 0,5$						
Color space	X Y INT siM (Lab)						
Teach button	external teaching of up to 3 colors (max. 64 in GROUP mode) via teach button at sensor housing via the corresponding evaluation mode, adjustable via PC software						
Color memory capacity	non-volatile EEPROM with parameter sets for max. 3 colors (max. 64 colors in GROUP mode)						
Housing dimensions	LxWxH approx. 50 mm x 50 mm x 27 mm (without flange connectors)						
Housing material	aluminum, anodized in black						
Enclosure rating	IP64						
Connecting cables	to PLC: cab-las8/SPS or cab-las8/SPS-w to PC/RS232 interface: cab-las4/PC or cab-las4/PC-w to PC/USB interface: cab-4/USB or cab-4/USB-w to PC/Ethernet interface: cab-4/ETH						
Type of connector	connection to PLC: 4-pole M8-connector, connection to PC: 4-pole fem. connector (Binder 707)						
Operating temp. range	-20 $^{\circ}\text{C}$... +55 $^{\circ}\text{C}$						
Storage temperature range	-20 $^{\circ}\text{C}$... +85 $^{\circ}\text{C}$						
EMC test acc. to	DIN EN 60947-5-2						

Dimensions

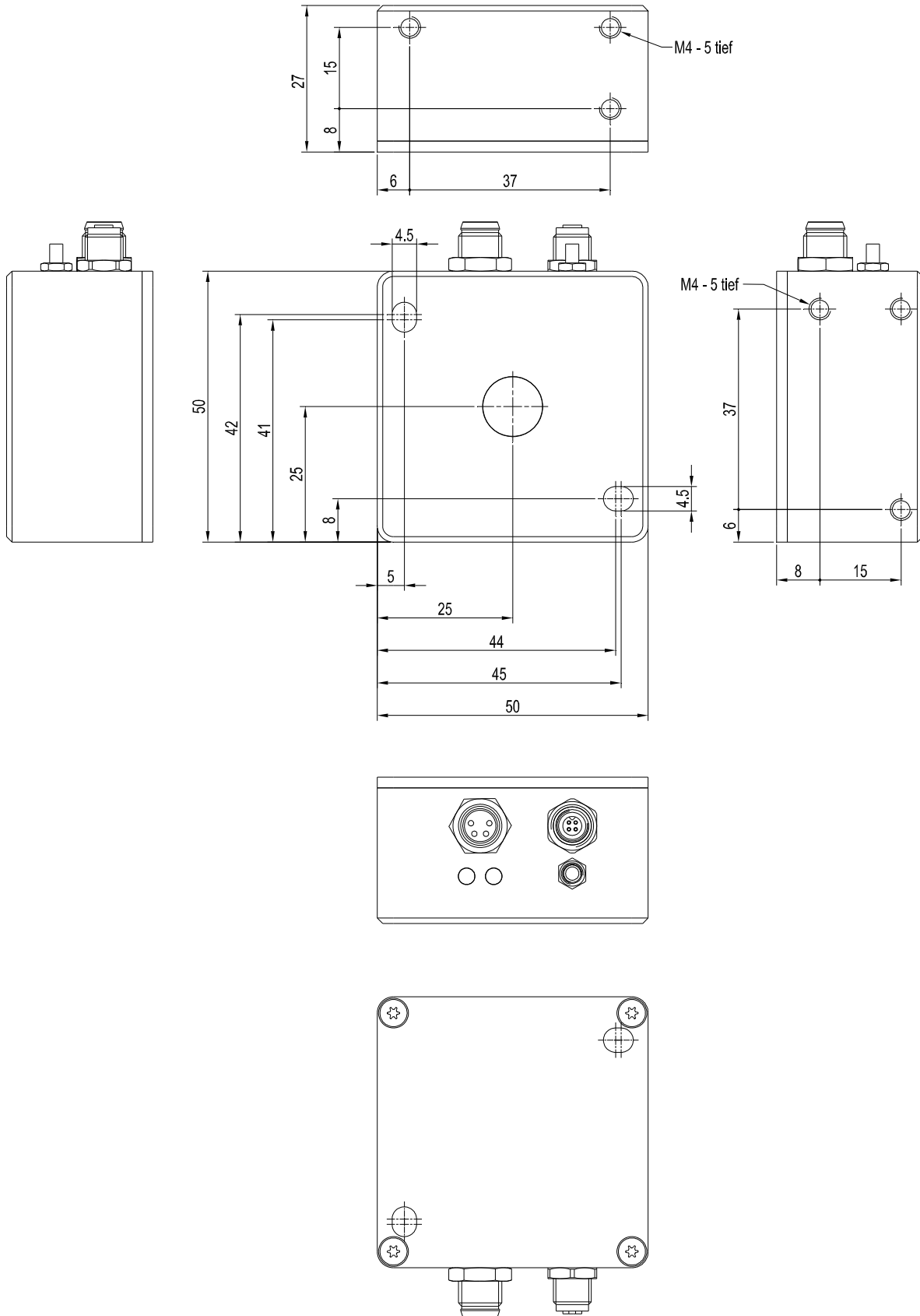

All dimensions in mm



Connector Assignment

Connection to PLC: 4-pole M8 connector

Pin:	Color:	Assignment:
1	brown	+Ub (+24VDC \pm 10%)
2	white	OUT0
3	blue	GND (0V)
4	black	OUT1

Connecting cable:
cab-M8/4-g-(length) or
cab-M8/4-w-(length) (angle type 90°)
(standard length 2m)

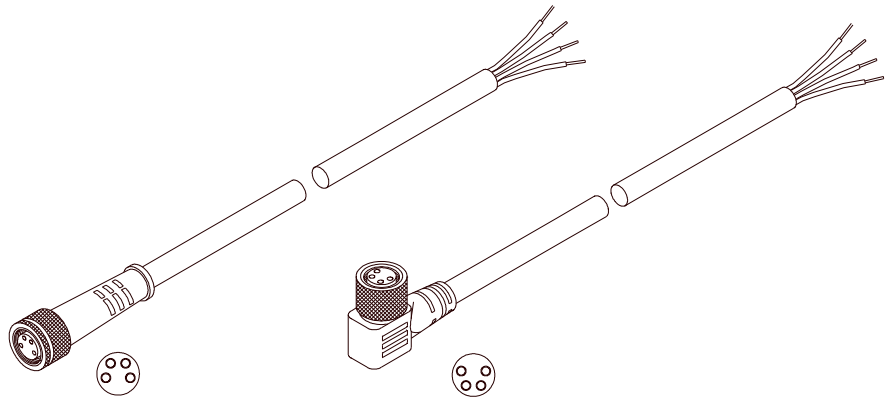

cab-M8/4-g-2-...
(max. length 5m, outer jacket: PUR)

cab-M8/4-w-...
(max. length 5m, outer jacket: PU)

Connection to PC: 4-pol. fem. connector Binder Series 707

Pin:	Assignment:
1	+24VDC (+Ub, OUT)
2	GND (0V)
3	RxD
4	TxD

Connection via RS232 interface at the PC:

Connecting cable:
cab-las4/PC-(length)
cab-las4/PC-w-(length) (angle type 90°)
(standard length 2m)

alternative:

Connection via USB interface at the PC:

USB converter (incl. driver software):
cab-4/USB-(length)
cab-4/USB-w-(length) (angle type 90°)
(standard length 2m)

alternative:

Connection to local network via Ethernet bus:

Ethernet converter (incl. software „SensorFinder“):
cab-4/ETH-500 (incl. software „SensorFinder“)
(standard length 500mm)

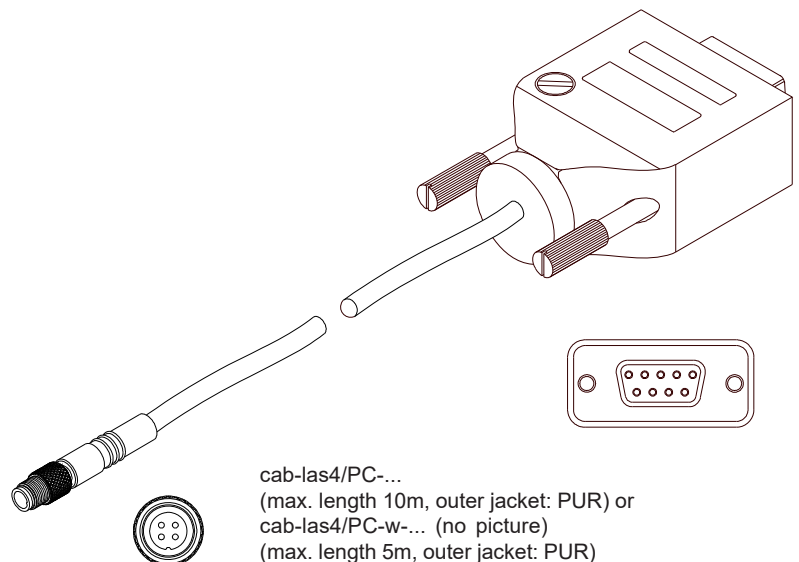

cab-las4/PC-...
(max. length 10m, outer jacket: PUR) or
cab-las4/PC-w-... (no picture)
(max. length 5m, outer jacket: PUR)

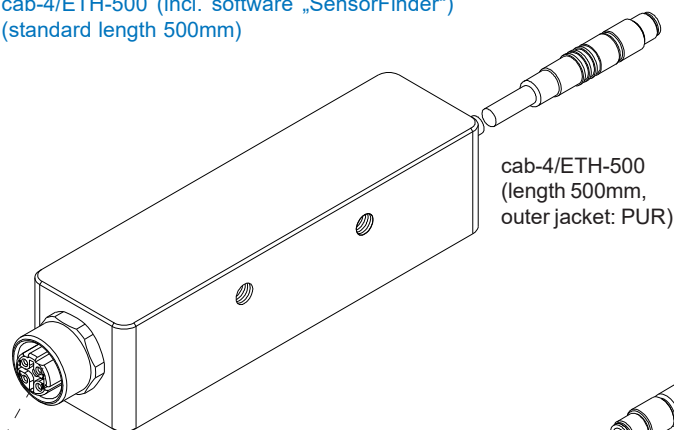

cab-4/ETH-500
(length 500mm,
outer jacket: PUR)

4-pole M12 fem. connector (D-coded) for
connection of an external CAT5 cable, e.g.
cab-eth/M12D-RJ45-flx-(length)
(available in length 2m, 5m, 10m, or 20m)

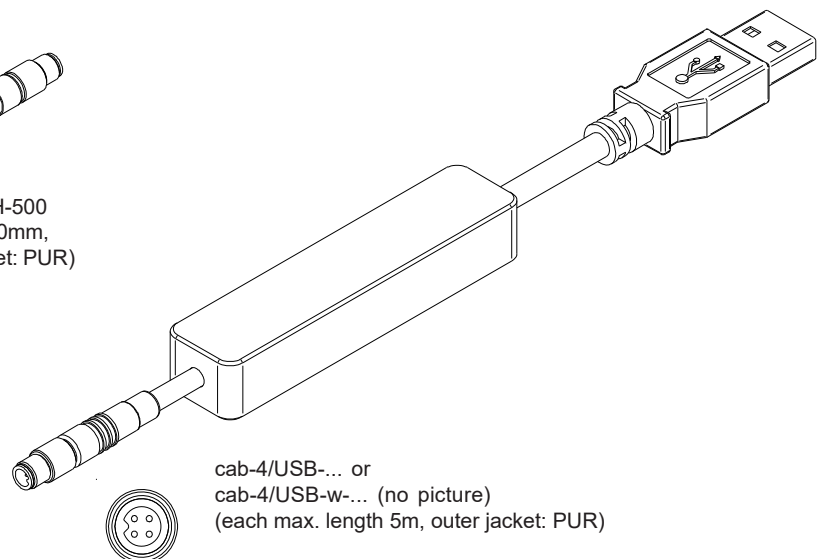

cab-4/USB-... or
cab-4/USB-w-... (no picture)
(each max. length 5m, outer jacket: PUR)



Measuring Principle

Measuring principle of color sensors of SPECTRO-3-...-SL Series:

The SPECTRO-3-...-SL provides highly flexible signal acquisition. For example, the sensor can be operated in alternating-light mode (AC mode), which makes the sensor insensitive to extraneous light. It also can be set to constant-light mode (DC mode), which makes the sensor extremely fast. An OFF function turns off the integrated light source at the sensor and changes to DC operation. The sensor then can detect so-called "self-luminous objects". With the stepless adjustment of the integrated light source as well as the selectable gain of the receiver signal and an INTEGRAL function the sensor can be set to almost any surface or any "self-luminous object".

When the integrated light source of the SPECTRO-3-...-SL color sensor is activated, the sensor detects the radiation that is diffusely reflected from the object. As a light source the SPECTRO-3-...-SL color sensor uses a white-light LED with adjustable transmitter power. An integrated 3-fold receiver for the red, green, and blue content of the light that is reflected from the object, or the light that is emitted by a "self-luminous object", is used as a receiver.

As a light source the SPECTRO-3-...-UV-SL color sensor uses a UV-LED (375 nm) with adjustable transmitter power to excite the luminescent marking. An integrated 3-fold receiver for the red, green, and blue content of the visible light that is emitted by the luminescent marking is used as a receiver. A special feature here is that the gain of the receiver can be set in 8 steps. This makes it possible to optimally adjust the sensor to almost any luminescent colorant that can be excited in the long-wave UV range.

The SPECTRO-3-...-SL color sensor can be "taught" up to 3 colors. For each of these taught colors it is possible to set tolerances. In "X Y INT - 2D" or "s i M - 2D" mode these tolerances form a color cylinder in space. In "X Y INT - 3D" or "s i M - 3D" mode the tolerances form a color sphere in space. Color evaluation according to "s i M - 2D" is based on the lab calculation method. All modes can be used in combination with several operating modes such as "FIRST HIT" and "BEST HIT". Raw data are represented with 12 bit resolution.

As a special feature the sensor can be taught two completely independent parameter sets. The push button at the sensor housing can then be used to tell the sensor which parameter set it should work with. Color detection either operates continuously or is started through an external PLC trigger signal. The respective detected color either is provided as a binary code at the 2 digital outputs or can be sent directly to the outputs, if only up to 2 colors are to be detected.

Through the push button at the sensor housing the color sensor can be taught up to 3 colors (64 colors in group mode). For this purpose the corresponding evaluation mode must be set with the software.

Parameters and measurement values can be exchanged between a PC and the SPECTRO-3-...-SL color sensor through the serial RS232 interface. All the parameters for color detection also can be saved to the non-volatile EEPROM of the SPECTRO-3-...-SL color sensor through this serial RS232 interface. When parameterisation is finished, the color sensor continues to operate with the current parameters in STAND-ALONE mode without a PC.

The sensors of the SPECTRO-3-...-SL series can be calibrated (white-light balancing). Balancing can be performed to any white surface. A ColorCheckerTM table with 24 color fields is available as an alternative. White-light balancing or calibration can be performed to one of the white, grey, or black fields.

The UV color sensors SPECTRO-3-...-UV-SL also can be calibrated. Analogous to white-light balancing with color sensors, balancing of the SPECTRO-3-...-UV-SL could be performed to any luminescent color marking.



LED Display

LED Display:

The two LEDs visualize the physical state of the outputs OUT0 und OUT1.

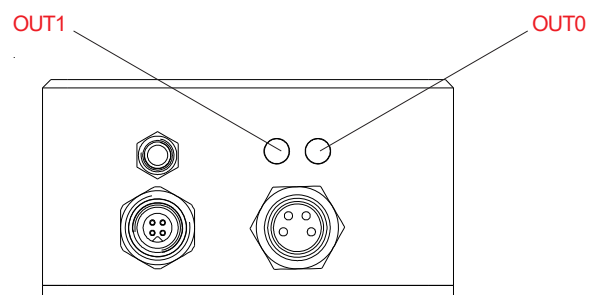



Parameterization

Windows® user interface SPECTRO3-SL-Scope:

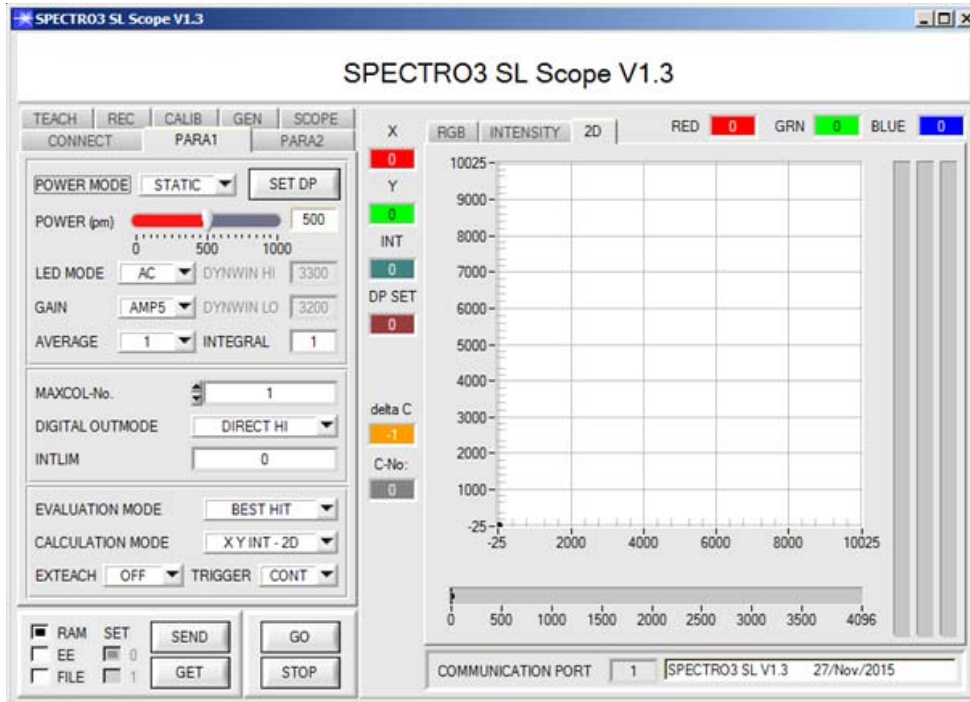

The PC software facilitates the parameterization, the diagnosis, and the adjustment of the sensor system (oscilloscope function). Moreover, the software features a data recorder function that allows the automatic recording of recorded data and the saving of those at the hard disk of the PC.

Parameters and measurement values can be exchanged between PC and sensor either through RS232 or Ethernet (using an Ethernet adaptor). Through the interface all the parameters can be stored in the non-volatile EEPROM of the sensor.

Under Windows® representation of the color value on a PC in numeric form and in a color chart, and representation of RGB values in a time chart. In addition the current RGB values are displayed as a bar chart.

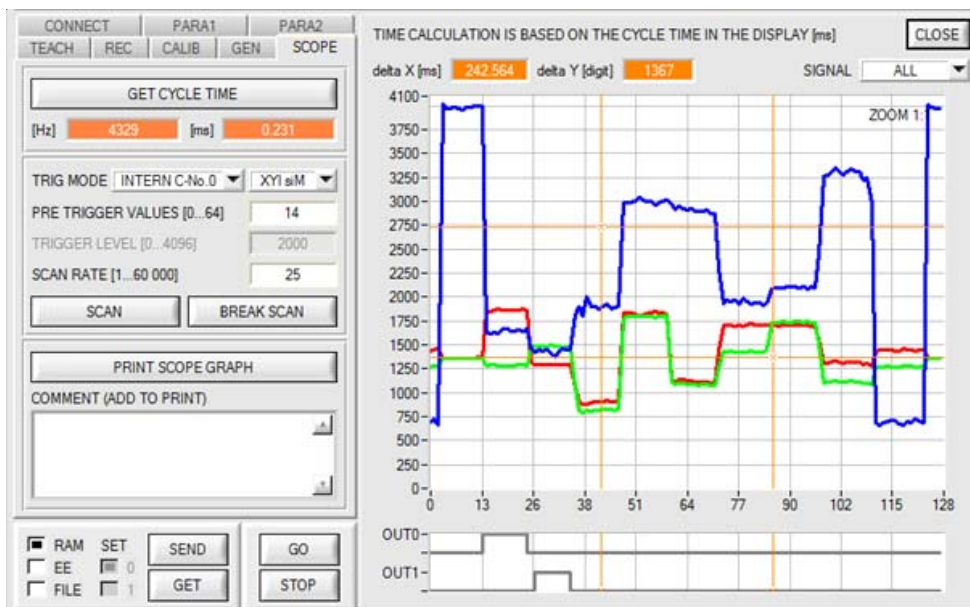

The SCOPE tab visualises an oscilloscope.

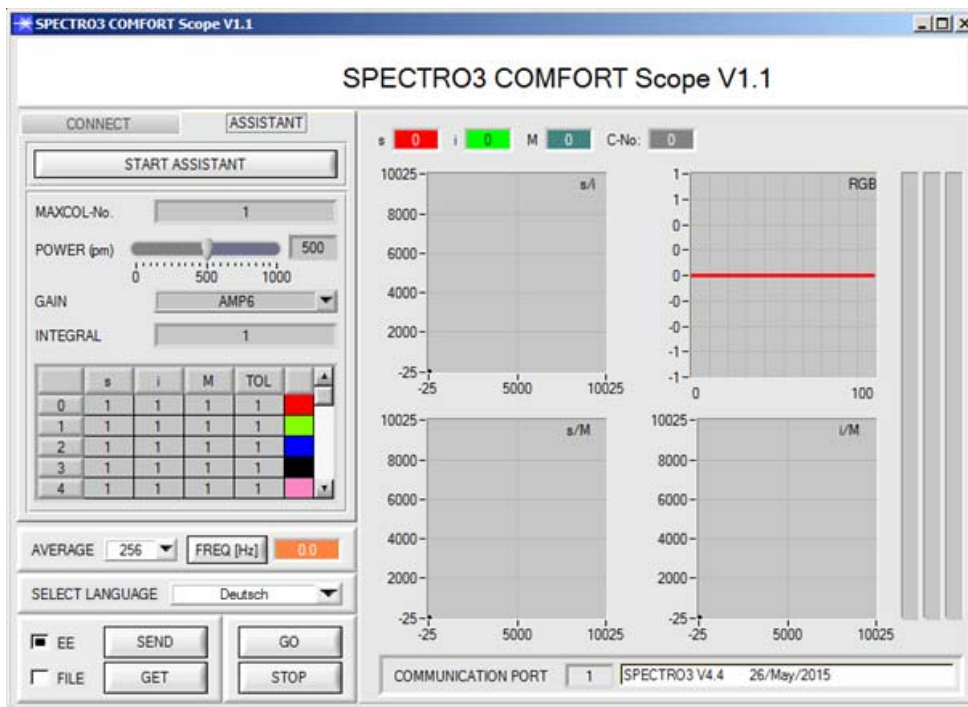

Parametrization
Windows® user interface SPECTRO3-COMFORT-Scope as an alternative to SPECTRO3-SL-Scope:

Color sensors of the following types can be quickly parameterised with the SPECTRO3-COMFORT-SCOPE software:

SPECTRO-3 (im M34 housing)
 SPECTRO-3-CL
 SPECTRO-3-JR
 SPECTRO-3-SL
 SPECTRO-3-SLE

The software features menu guidance that prompts the user to enter all the relevant parameters.

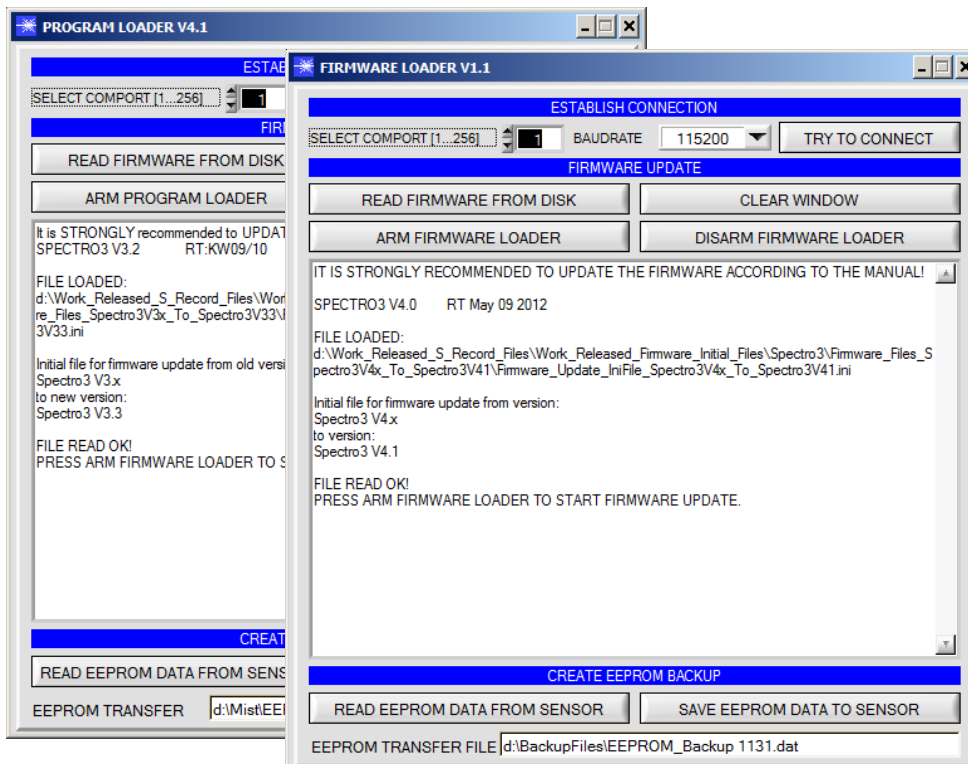

Firmware Update
Firmware update by means of software „ProgramLoader“ or „FirmwareLoader“:

The software „ProgramLoader“ or „FirmwareLoader“ allows the user to perform an automatic firmware update. The update will be carried out through the RS232 interface.

An initialisation file (xxx.ini) and a firmware file (xxx.elf.S) are required for performing a firmware update. These files can be obtained from your supplier. In some cases an additional firmware file for the program memory (xxx.elf.p.S) is also needed, and this file will be automatically provided together with the other two files.



Diagrams

Diagramme: DETECTION RANGE (HALF INTENSITY WIDTH) and RELATIVE INTENSITY SPECTRO-3-DIL-SL

Detection range (half intensity width)
 SPECTRO-3-DIL-SL:
 12 mm (typ.) at a working distance of 20 mm

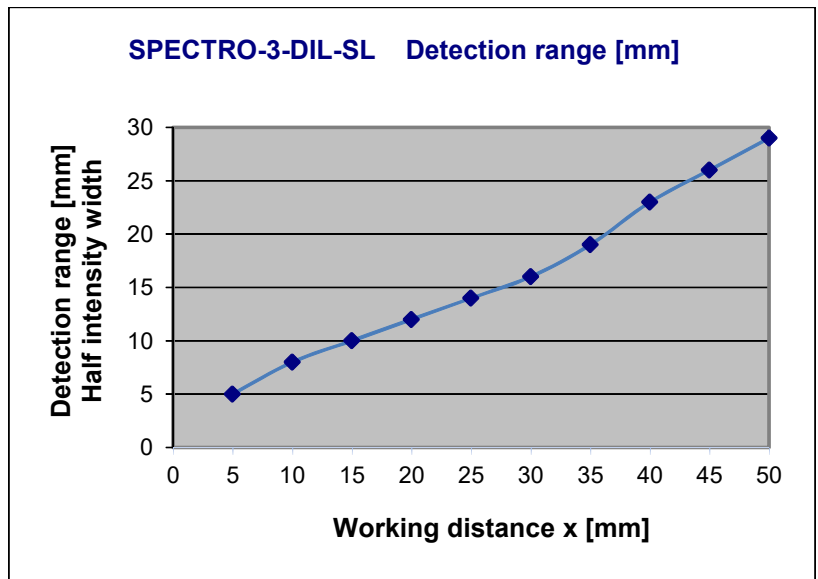

Relative Intensity:
 SPECTRO-3-DIL-SL:
 100% at a working distance of 3 mm
 (INTENSITY 3627)

