

FIA Series

► FIA-L-08-...-P-IR

- Infrared laser light beam
- Class 1 laser product (850 nm, P<0.39 mW)
- Integrated electronics
- Switching state indicator (yellow LED)
- Scratch-resistant optics
- 4-pole M8-connector
- Sturdy aluminum housing
- Compact design
- Insensitive to dirt accumulation, insensitive to outside light
- High switching frequency (typ. 25 kHz)

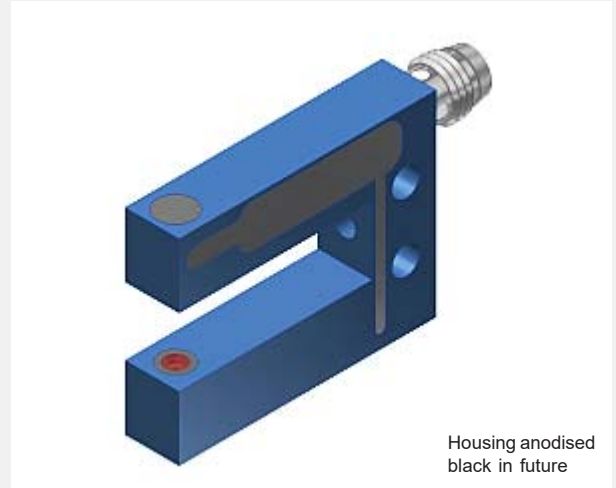

Housing anodised black in future



Design

Product name:

FIA-L-08-(aperture)-(fork size)-P-IR

available apertures:

- d0.4** (circular aperture Ø 0.4 mm)
- d0.6** (circular aperture Ø 0.6 mm)
- d0.8** (circular aperture Ø 0.8 mm)
- d1.0** (circular aperture Ø 1.0 mm)
- d1.2** (circular aperture Ø 1.2 mm)

Available fork sizes: (cf. dimensions page 3)

- 10/15** (fork width A=10 mm, fork depth B=15 mm)
- 10/25** (fork width A=10 mm, fork depth B=25 mm)
- 10/30** (fork width A=10 mm, fork depth B=30 mm)
- 20/15** (fork width A=20 mm, fork depth B=15 mm)
- 20/30** (fork width A=20 mm, fork depth B=30 mm)
- 25/50** (fork width A=25 mm, fork depth B=50 mm)
- 25/80** (fork width A=25 mm, fork depth B=80 mm)
- 30/15** (fork width A=30 mm, fork depth B=15 mm)
- 30/30** (fork width A=30 mm, fork depth B=30 mm)

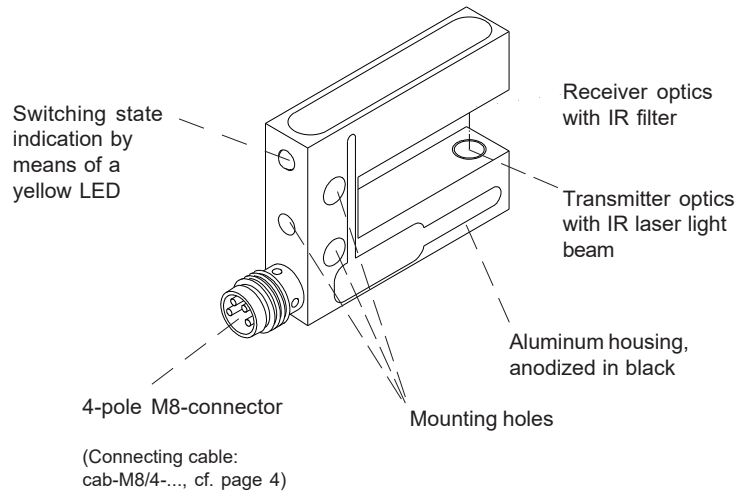



Technical Data

Type	FIA-L-08-...-P-IR
Light source	Solid state laser 850 nm, AC operation, 0.39 mW max. opt. power, laser class 1 acc. to DIN EN 60825-1. The use of these laser transmitters therefore requires no additional protective measures.
Min. detectable object	typ. 0.3 mm
Reproducibility	typ. 0.01 mm
Optical filter	IR block filter
Voltage supply	+24VDC (± 10%), reverse polarity protected
Ambient light	up to 5000 Lux
Current consumption	typ. 20 mA
Aperture size	Circular apertures Ø 0.4 mm / Ø 0.6 mm / Ø 0.8 mm / Ø 1.0 mm / Ø 1.2 mm
Switching outputs (2x)	Q = pnp bright-switching (pnp n.c.) / npn dark-switching (nnp n.o.) Qinv = pnp dark-switching (pnp n.o.) / npn bright-switching (nnp n.c.) 100mA, short-circuit protection
Enclosure rating	IP67
Operating temperature range	-20°C ... +50°C
Storage temperature range	-20°C ... +85°C
Housing material	Aluminum, anodized in black
Housing dimensions	see page 3
Connector type	4-pole M8-connector
EMC test acc. to	DIN EN 60947-5-2 
Switching frequency	typ. 25 kHz
Switching state indicator	by means of a yellow LED integrated in the sensor housing LED on = sensor free LED off = sensor covered



Laser Information

The laser transmitter of FIA-L Series comply with laser class 1 according to EN 60825-1. Under reasonably foreseeable conditions a class 1 laser is safe. The reasonably foreseeable conditions are kept during specified normal operation. The use of these laser transmitters therefore requires no additional protective measures.

The laser transmitter of FIA-L Series are supplied with an information label „CLASS 1 LASER PRODUCT“.

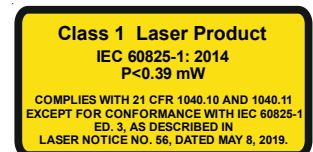

Dimensions

FIA-L-08-...-P-IR:

Fork size	dim. A	dim. B
10/15	10 mm	15 mm
10/25	10 mm	25 mm
10/30	10 mm	30 mm
20/15	20 mm	15 mm
20/30	20 mm	30 mm
25/50	25 mm	50 mm
25/80	25 mm	80 mm
30/15	30 mm	15 mm
30/30	30 mm	30 mm

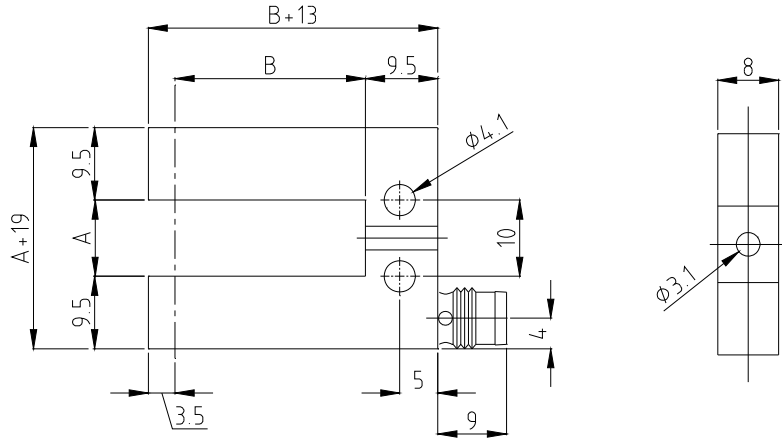

(All dimensions in mm)

Connector Assignment

Connector assignment FIA-L-08-...-P-IR:
(4-pole M8-connector)

Pin:	Assignment:
1	+Ub (+24VDC \pm 10%)
2	Qinv (pnp dark-switching, npn bright-switching)
3	0V (GND)
4	Q (pnp bright-switching, npn dark-switching)

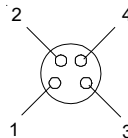

Available connecting cables:

- cab-M8/4-g-2** (l=2m)
- cab-M8/4-g-5** (l=5m)
- cab-M8/4-w-2** (angle type, l=2m)
- cab-M8/4-w-5** (angle type, l=5m)

