

SI-COLO Series

▶ SI-COLO4-80-FCL-POL

- Measuring range typ. 40 mm ... 100 mm
- Focused white-light area (for dark/mat surfaces)
- Polarisation filter (for reduction of gloss effect)
- Up to 31 colors can be stored
- 12x white-light LED, 30 kHz modulated, focused
- Color and gray scale detection
- Insensitive to outside light
- Brightness correction can be activated
- Several TEACH functions (via PC, PLC, or push button)
- RS232 interface (USB or Ethernet adapter is available)
- Various evaluation algorithms can be activated
- Switching state display by means of 5 yellow LEDs
- 'Averaging' can be activated (from 1 up to over 32000 values)
- Material adaptation can be activated („Adaptive Control“)

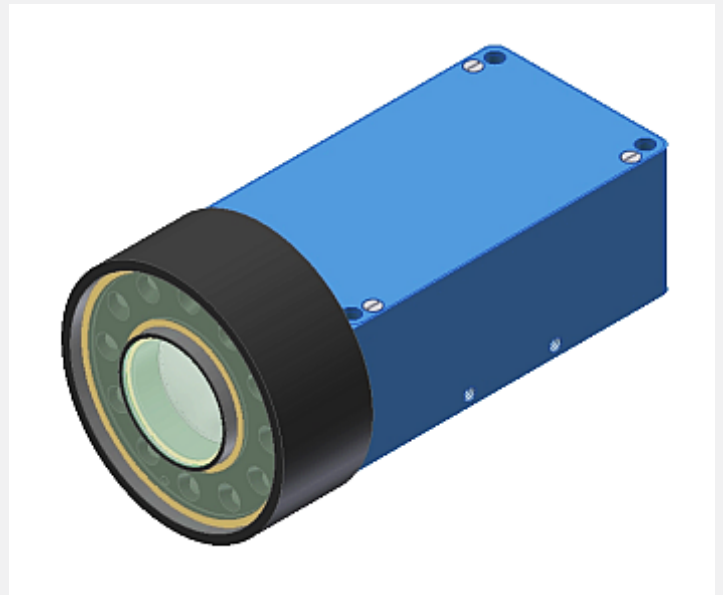

Design

Product name:

SI-COLO4-80-FCL-POL

(incl. Windows® PC software SI-COLO4-Scope)

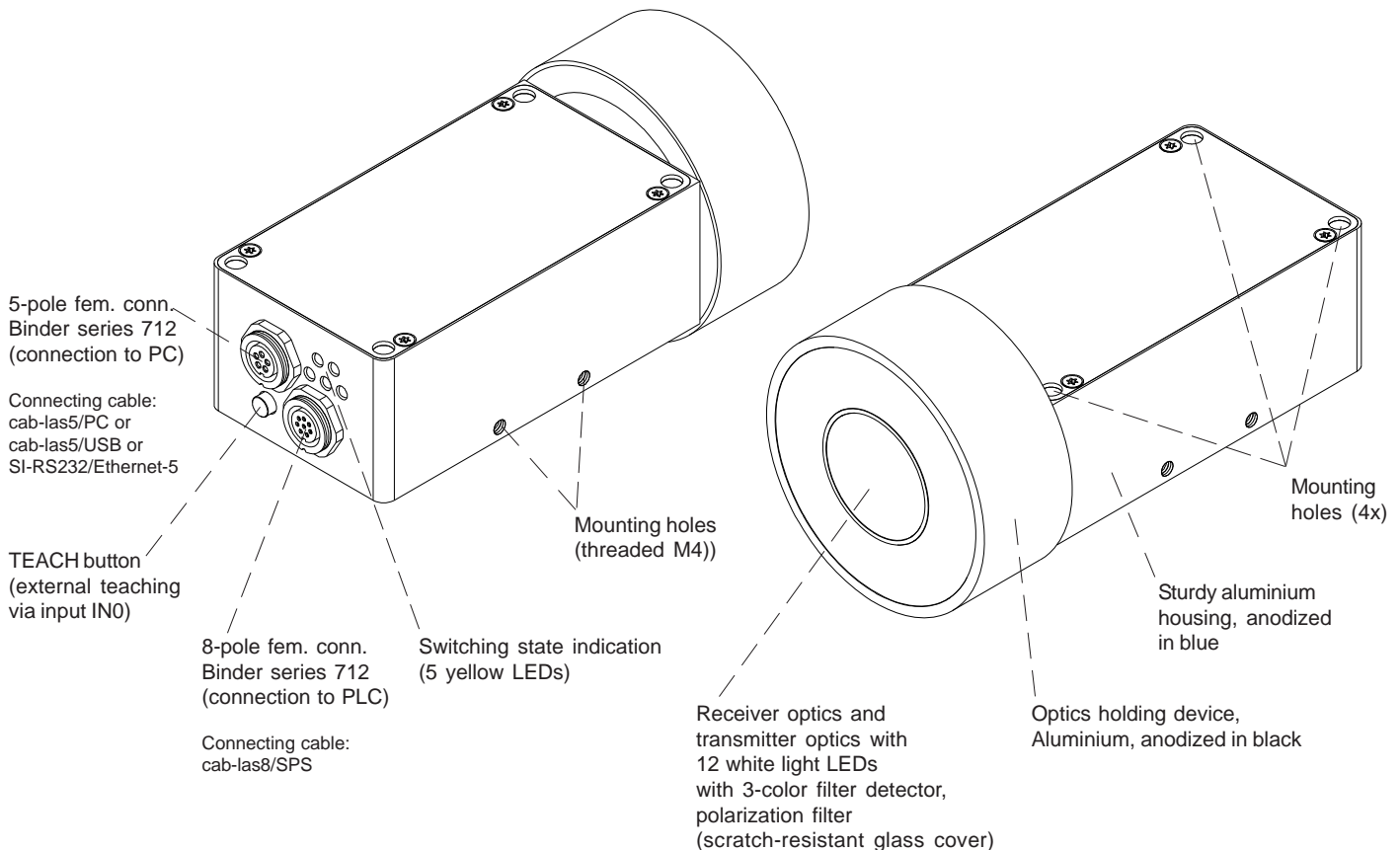



Technical Data

Type	SI-COLO4-80-FCL-POL
Light source	12x white-light LED, modulated 30 kHz, focused, polarization filter
Target distance	typ. 40 mm ... 100 mm
Detection range (half intensity width)	typ. 30 mm (at a distance of 40 mm) ... typ. 40 mm (at a distance of 100 mm)
Reproducibility	In the X,Y color range 1 digit each at 12 bit A/D conversion
Receiver	3-color filter detector
Alternating light operation	30 kHz
Ambient light	up to 5000 Lux
Type of protection	IP64
Current consumption	<320 mA
Interface	RS232, parameterizable under Windows®
Connector type	Connection to PLC: 8-pole female connector (Binder series 712) Connection to PC: 5-pole female connector (Binder series 712)
Connecting cables	to PLC: cab-las8/SPS or cab-las8/SPS-w to PC/RS232 interface: cab-las5/PC or cab-las5/PC-w to PC/USB interface: cab-las5/USB or cab-las5/USB-w, to PC/Ethernet interface: SI-RS232/Ethernet-5
EMC test acc. to	DIN EN 60947-5-2
Housing material	Aluminum, anodized in blue; optics holding device made of aluminum, anodized in black
Housing dimensions	LxWxH approx. 115 mm x 50 (Ø62) mm x 35 mm (without connector flanges)
Operating temperature range	-20°C ... +55°C
Storage temperature range	-20°C ... +85°C
Pulse lengthening	adjustable under Windows® 0 ms ... 100 ms
Max. switching current	100 mA, short-circuit protected
Switching frequency	max. 30 kHz (depends on the number of teach-colors and averaging value)
Input digital (1x)	IN0 (Pin 3), digital (0V/+24V) or teach button at the housing
Outputs digital (5x)	OUT 0 ... OUT 4, digital (0V/+Ub), npn/pnp-output available (bright-, dark-switching can be switched over)
Averaging	over 32768 values max.
Voltage supply	+24VDC (± 10%), protected against polarity reversal, overload protected
Switching state display	Visualization by means of 5 yellow LEDs
Color memory capacity	non-volatile EEPROM with parameter sets for 31 colors max.
TEACH button	for external teaching of color reference values via input IN0
Temperature drift X,Y	$\Delta X/\Delta T$; $\Delta Y/\Delta T$ typ. 0,3 digits/°C (< 0,01% / °C)

Dimensions

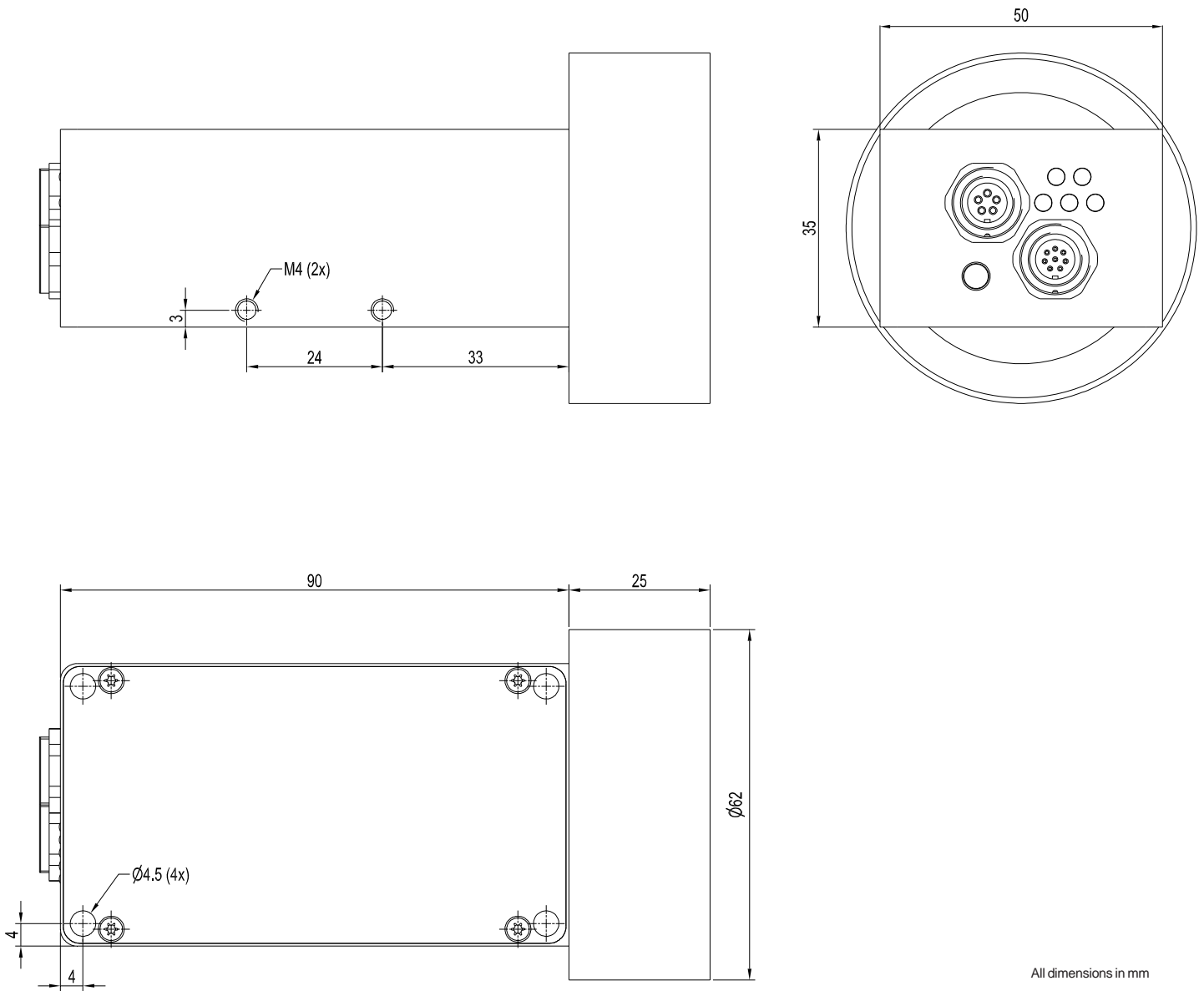

All dimensions in mm

 Connector Assignment

Connection to PLC:
8-pole fem. connector Binder Series 712

Pin: Color: Assignment:

1	white	GND (0V)
2	brown	+24VDC ($\pm 10\%$)
3	green	IN0
4	yellow	OUT0 (Digital 0: typ. 0...1V, Digital 1: typ. +Ub - 10%)
5	grey	OUT1 (Digital 0: typ. 0...1V, Digital 1: typ. +Ub - 10%)
6	pink	OUT2 (Digital 0: typ. 0...1V, Digital 1: typ. +Ub - 10%)
7	blue	OUT3 (Digital 0: typ. 0...1V, Digital 1: typ. +Ub - 10%)
8	red	OUT3 (Digital 0: typ. 0...1V, Digital 1: typ. +Ub - 10%)

Connecting cable:

cab-las8/SPS-(length)

cab-las8/SPS-w-(length) (angle type, 90°)

(standard length 2m)

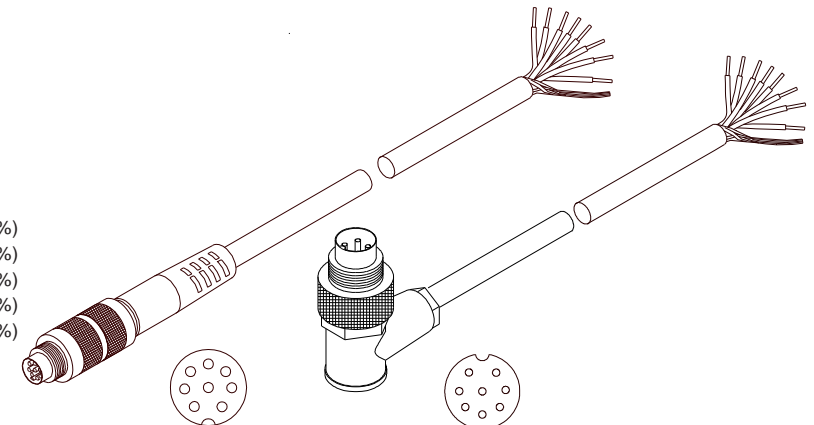
 cab-las8/SPS-...
 (max. length 25m,
 outer jacket: PUR)

 cab-las8/SPS-w-...
 (max. length 25m,
 outer jacket: PUR)

Connection to PC:
5-pole fem. connector Binder Series 712

Pin: Assignment:

1	GND (0V)
2	TxD
3	RxD
4	+24V (+Ub, OUT)
5	not connected

Connection via RS232 interface at the PC:
Connecting cable:

cab-las5/PC-(length)

cab-las5/PC-w-(length) (angle type 90°)

(standard length 2m)

alternative:
Connection via USB interface at the PC:

Connecting cable (incl. driver software):

cab-las5/USB-(length)

cab-las5/USB-w-(length) (angle type 90°)

(standard length 2m)

alternative:
Connection to local network via Ethernet bus:

Adapter (based on Lantronix XPortModul):

SI-RS232/Ethernet-5-(length)

(standard length 2m)

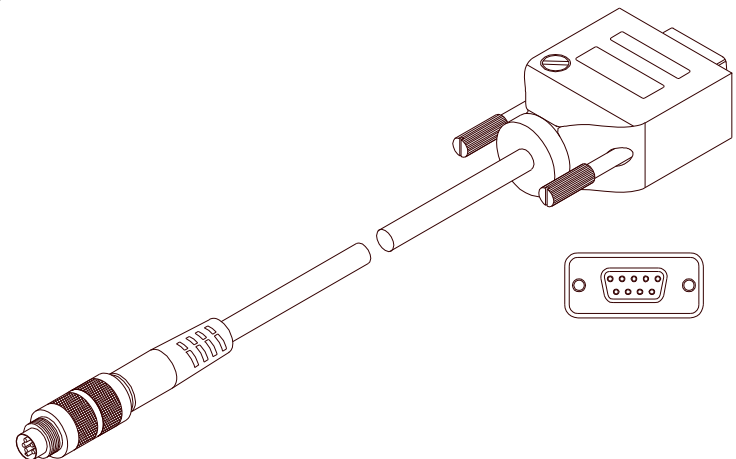
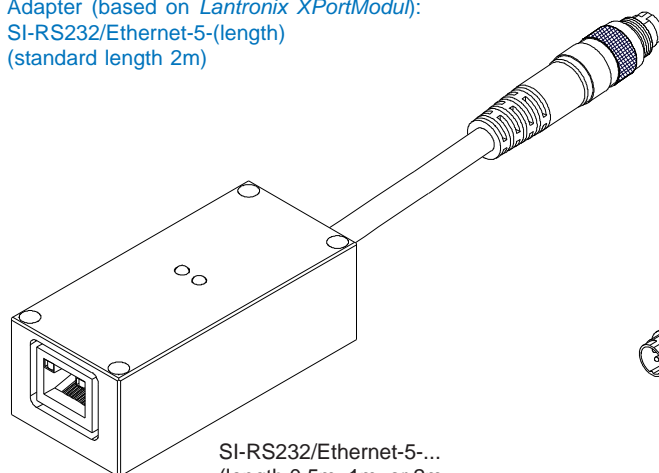
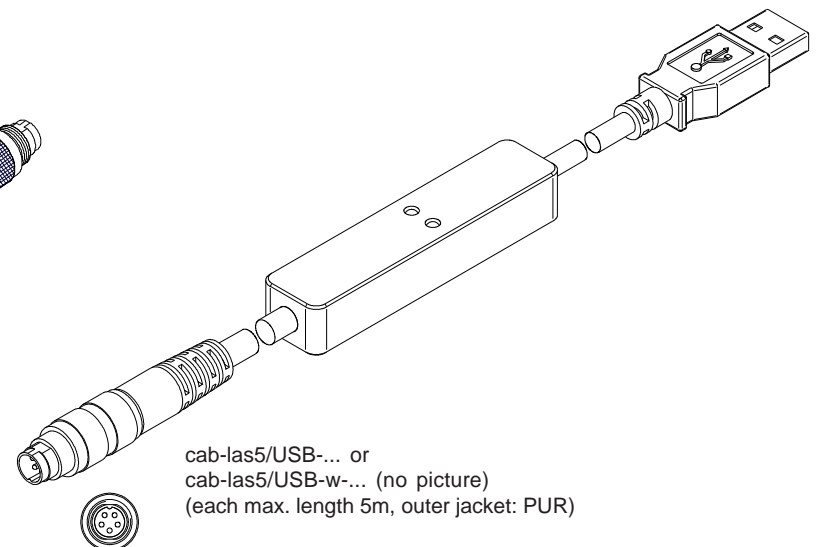
 cab-las5/PC-...
 (max. length 10m, outer jacket: PUR) or
 cab-las5/PC-w-... (no picture)
 (max. length 5m, outer jacket: PUR)

 SI-RS232/Ethernet-5-...
 (length 0.5m, 1m, or 2m,
 outer jacket: PUR)

 cab-las5/USB-... or
 cab-las5/USB-w-... (no picture)
 (each max. length 5m, outer jacket: PUR)



Measuring Principle
Measuring principle of the SI-COLO4 color sensor:

The SI-COLO4 color sensor detects the radiation that is diffusely reflected by the target. The SI-COLO4 color sensor uses a white-light LED with adjustable power as a light source. A triple receiver for the RED, GREEN, and BLUE content of the light reflected from the target is used as a receiver. With the stepless adjustment of the integrated light source and the selectable gain of the receiver signal the sensor can be set to almost any surface. The SI-COLO4 color sensor can be "taught" up to 31 colors. Tolerances can be set for every taught color.

In X/Y INT or s/i M mode the tolerances represent a color cylinder in space. In X/Y/INT or s/i/M mode the tolerance represents a color sphere in space. Color evaluation according to s/i M and s/i/M uses the Lab calculation method. All the modes can be used in combination with various operating modes, among others "FIRST HIT" and "BEST HIT". The raw data are represented with 12 bit resolution.

Color detection either operates continuously or is started by means of an external SPC trigger signal. The respective detected color either is output as binary code at the 5 digital outputs, or it can be sent directly to the outputs, if only up to 5 colors are to be detected. Simultaneously the detected color code is visualised at the SI-COLO4 housing by means of 5 LEDs.

With the TEACH button at the sensor housing the sensor can be taught up to 31 colors. For this purpose the corresponding evaluation mode must be set with the software. The TEACH button is connected in parallel to the input IN0 (green wire of cable cab-las8/SPS).

Through the RS232 interface parameters and measured values can be exchanged between the PC and the SI-COLO4 color sensor. All the parameters for color detection can be stored in the non-volatile EEPROM of the SI-COLO4 color sensor. When parameterization is finished the color sensor continues to operate with the current parameters in "stand alone" mode without a PC.

The sensors of the SI-COLO4 V6.4 series can be calibrated (white light balancing). Balancing can be performed to any white surface. A ColorChecker™ table with 24 color fields according to CIE standard is available as an alternative, and white light balancing or calibration can then be performed to one of the white fields.



Parameterization
Windows® user interface:

The color sensor is parameterized under Windows® with the SI-COLO4-Scope software. The Windows® user interface facilitates the teach-in process at the color sensor and supports the operator in the task of adjustment and commissioning of the color sensor.

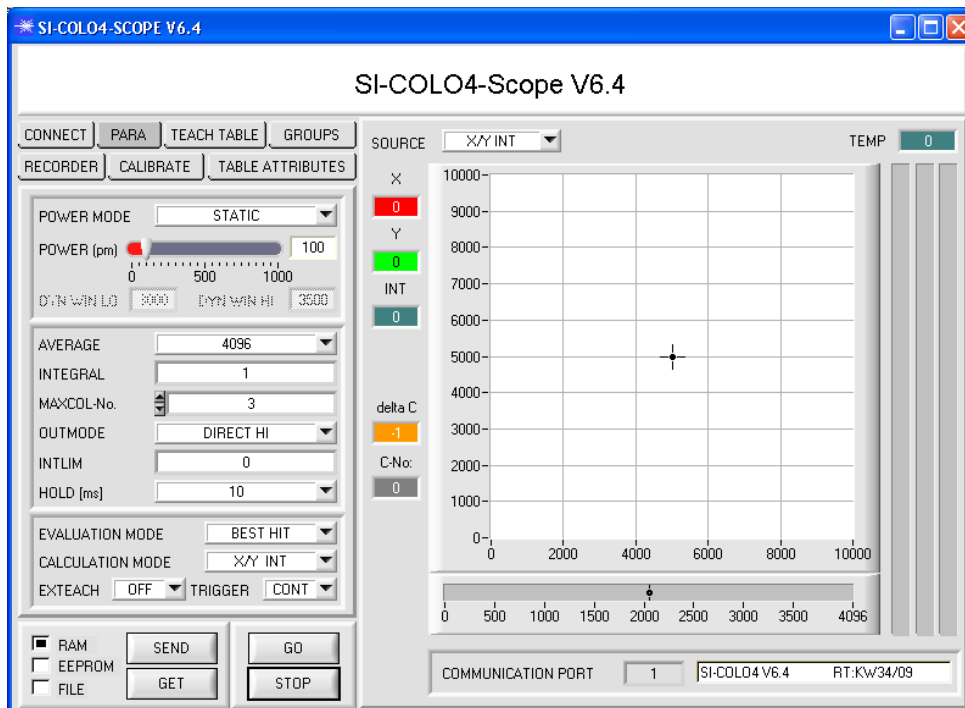

The RS232 interface (tab PARA) is used for setting parameters such as:

- POWER-MODE:
Light power of the white-light LED
- AVERAGE:
Averaging over a maximum of 32768 values
- INTEGRAL:
This function field is used to set the number of scan values (measurement values) over which the raw signal measured at the receiver is summed up. This integral function allows the reliable detection even of extremely weak signals
- TRIGGER:
Continuous or external or self trigger
- MAXCOL-No.:
Number of colors to be checked
- COLOR GROUPS:
Forming of color groups
- OUTMODE:
Triggering of the digital outputs
- INTLIM:
Minimum intensity required for color evaluation
- HOLD:
Pulse lengthening up to 100ms max.

Under Windows® representation of the color value on a PC in numeric form and in a color chart, and representation of RGB values in a time chart. In addition the current RGB values are displayed as a bar chart.

Parameterization

Offset calibration:

To avoid an increase of the electronic offset when using the integral function (INTEGRAL parameter), this offset can be eliminated by way of offset calibration or zero-point calibration. The corresponding tab is password-protected to prevent inadvertent incorrect settings.

Graphic display elements:

SOURCE XY

SOURCE:

A click on the arrow button opens a selection field for the selection of a display mode in the graphic display window.

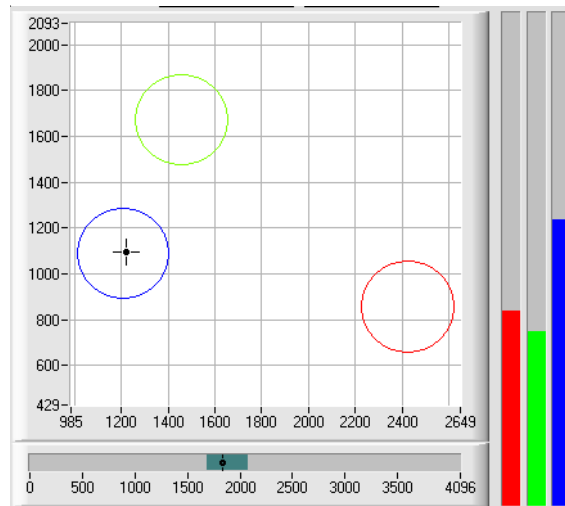

X/Y INT bzw. s/i M:

X/Y or s/i pairs are displayed in a zoomed graph. The intensity INT or M with the tolerance window set under No.: is shown directly below. Two-side view of the color cylinder in space.

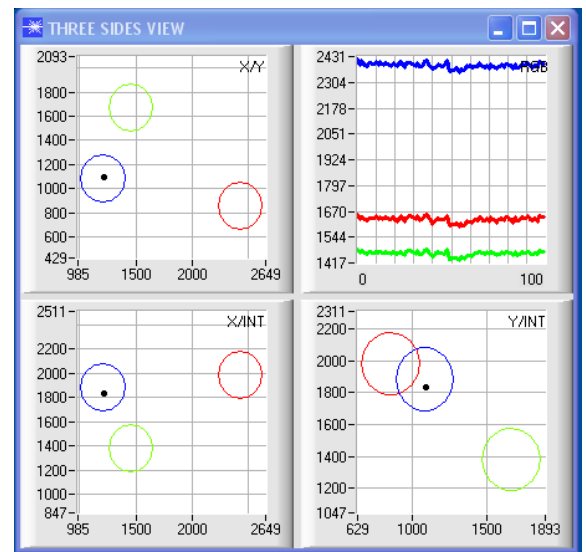

X/Y/INT bzw. s/i/M:

A panel opens that shows the taught color spheres and the current color position. For improved representation a three-side view with the graphs X/Y (s/i), X/INT (s/M) and Y/INT (i/M) was chosen.

TEMP 27

TEMP:

This display shows the temperature prevailing in the sensor housing. The display DOES NOT show degrees Centigrade or Fahrenheit.

delta C -1

delta C:

This display (delta color) shows the deviation from a color hit, delta C corresponds with ΔE that is calculated in a color measurement.

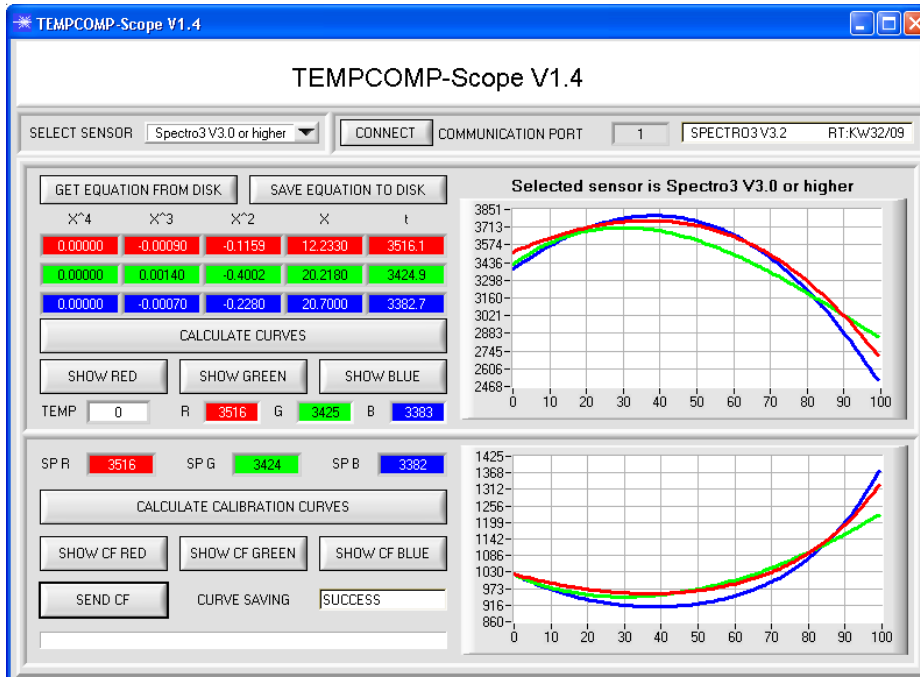

 Parameterization

Operation of the TEMPCOMP-Scope software:

If a firmware update should go wrong and the temperature characteristics that are stored in the EEPROM should be lost, these characteristics must be created anew. For this purpose you will need a file with the corresponding data. This file can be obtained from your supplier.

To perform temperature compensation please start the corresponding TEMPCOMP-Scope software that is included on the supplied CD. Please make sure that you have a functioning sensor connection. It may be necessary to select the connection with CONNECT. Set the correct sensor under SELECT SENSOR, if this is not done automatically.

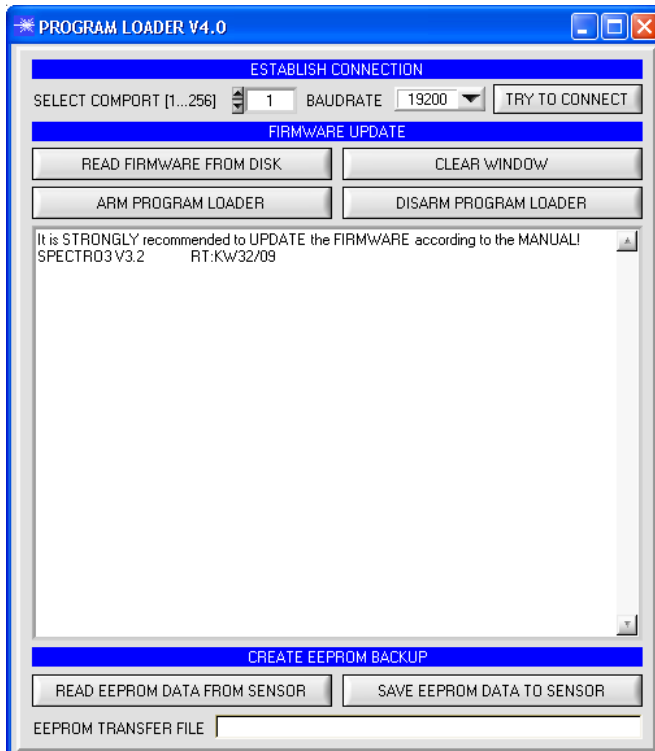
 Firmware Update

Firmware Update by means of the software Program Loader:

The software „Program Loader“ allows the user to perform an automatic firmware update. The update will be carried out through the RS232 interface.

An initialisation file (xxx.ini) and a firmware file (xxx.elf.S) are required for performing a firmware update. These files can be obtained from your supplier. In some cases an additional firmware file for the program memory (xxx.elf.p.S) is also needed, and this file will be automatically provided together with the other two files.

A plausibility check is performed after the initialisation file has been loaded with the Program Loader. If the initialisation file was changed or damaged, it will not be possible to perform a firmware update.

When the plausibility check is successfully completed, the instructions contained in the initialisation file will be carried out step by step.

The complete memory contents of the micro-controller in the sensor will be deleted in a firmware update. This means that both the program in the program memory and the data in the data memory will be lost.

The new firmware automatically writes the correct data to the program memory again.

However, the parameter settings, temperature curves, linearization curves, etc. that are stored in the data memory (EEPROM) will be deleted.

With the Program Loader V4.0 software the data will be saved in the EEPROM, and can be written back again after successful firmware update. For this purpose the software creates an EEPROM backup file.



LED Display

Visualization of the color code:

The color code is visualized by means of 5 yellow LEDs at the housing of the color sensor. At the same time the color code indicated at the LED display is output as 5-bit binary information at the digital outputs OUT0 ... OUT4 of the 8-pole PLC connector.

In the DIRECT mode the maximum number of color codes to be taught is 5. These 5 color codes can be directly output at the 5 digital outputs. The respective detected color code is displayed by means of the 5 yellow LEDs at the color sensor housing.

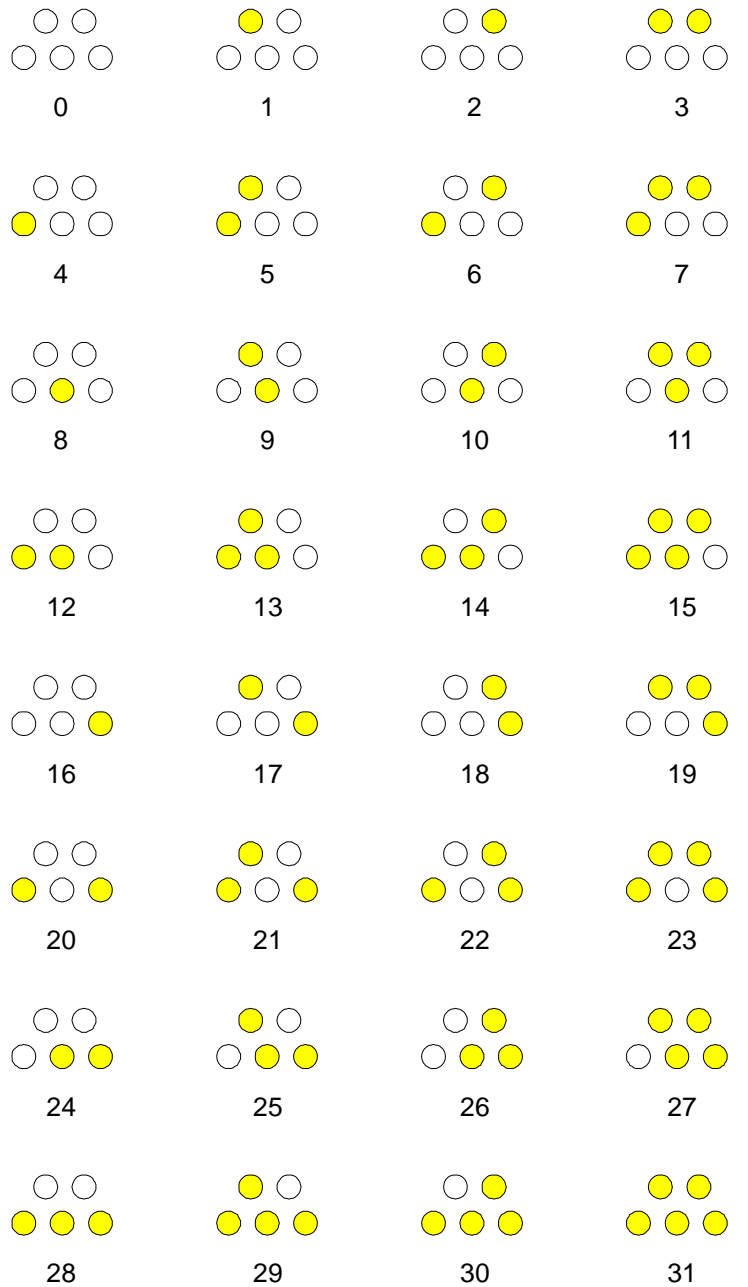
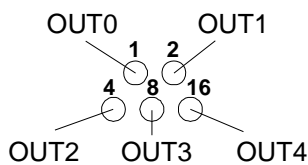
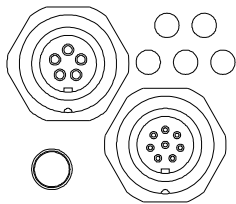

„Error“ or „not detected“