

L-LAS Series

▶ L-LAS-LT-80-HS-MA/-SL (High Speed, Master/Slave)

- Line laser <1 mW, wave length 670 nm, laser class 2
- Visible red laser line, typ. 1 mm x 3 mm
- Measuring range Master, Slave: each typ. 18 mm
- Start of measuring range Master/Slave: each at typ. 71 mm
- Resolution Master, Slave: each typ. 10 µm
- Integrated interference filter and red light filter
- CCD line detector with 512 pixel, 2048 pixel
- External teach button and potentiometer for tolerance setting
- RS232 interface (USB or Ethernet adaptor available)
- Windows® user interface
- 2 digital inputs, 3 digital outputs
- 1 analog output (voltage 0...+10V, optional current 4...20mA)
- Scan frequency max. 600 Hz
- Switching state indication via 4 LEDs (1x grn, 2x red, 1x yel)
- Optics cover made of scratch-resistant glass



Design

Product name:

- L-LAS-LT-80-HS-MA** (Master, analog 0...+10V)
- L-LAS-LT-80-HS-MA-4/20** (Master, analog 4...20mA)
- L-LAS-LT-80-HS-SL** (Slave)
- (incl. Windows® PC software L-LAS-LT-MS-Scope)

Accessories: (cf. p. 13-14)

- C-MOUNT-LT-80**
(Mounting plate, adjustable distance Master/Slave)

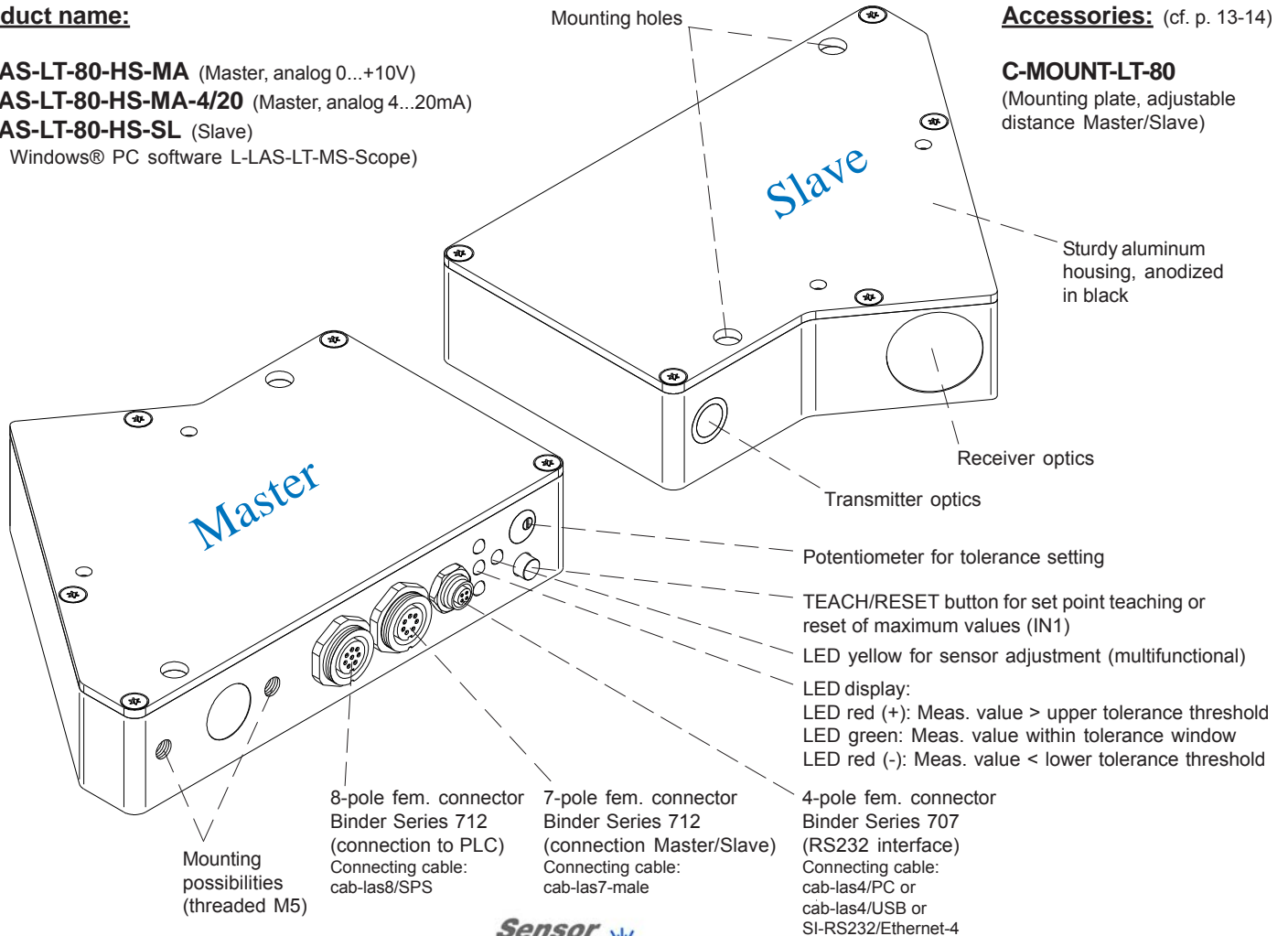



Technical Data

Model	L-LAS-LT-80-HS-MA L-LAS-LT-80-HS-SL	L-LAS-LT-80-HS-MA-4/20 L-LAS-LT-80-HS-SL
Light source	Semi-conductor laser, 670 nm, DC operation, 1 mW max. opt. power, laser class 2 acc. to DIN EN 60825-1. The use of these laser transmitters therefore requires no additional protective measures.	
Measuring range	MA and SL: each typ. 18 mm	
Start of measuring range	MA and SL: each typ. 71 mm (measured from housing edge, cf. picture beam path)	
End of measuring range	MA and SL: each typ. 89 mm (measured from housing edge, cf. picture beam path)	
Resolution	MA and SL: each typ. 10 µm (i.e. 2x 10 µm)	
Reproducibility	MA and SL: each typ. ± 10 µm (i.e. 2x ± 10 µm)	
Linearity	MA and SL: each 0.2% FSR (full scale range) (i.e. 2x 0.2%)	
Laser line geometry	typ. 1 mm x 3 mm	
Optical filter	Interference filter, red light filter	
Analog output (1x)	voltage output (0 ... +10V)	current output (4 ... 20mA)
Digital outputs (3x) (OUT0, OUT1, OUT2)	pnp bright-switching / npn dark-switching or pnp dark-switching / npn bright-switching, adjustable under Windows®, 100 mA, short-circuit proof	
Digital inputs (2x) (IN0, IN1)	IN0: External trigger, IN1: Teach/Reset (double function) input voltage +Ub/0V, with protective circuit	
Voltage supply	+24VDC (± 10%)	
Sensitivity setting	adjustable via potentiometer TOL or under Windows® via PC	
Laser power correction	adjustable under Windows® via PC	
Current consumption	typ. 200 mA	
Enclosure rating	electronics: IP54, optics: IP67	
Temperature stability	0.01% of measuring range/°C	
Temperature ranges	operating temperature range: -10°C ... +50°C, storage temperature range: -20°C ... +85°C	
Housing material	aluminium, anodized in black	
Housing dimensions	each Master and Slave: LxWxH approx. 120 mm x 86.57 mm x 25 mm (without flange connectors)	
Type of connector	L-LAS-LT-80-HS-MA: 8-pole circular fem. connector type Binder 712 (PLC/Power) 4-pole circular fem. connector type Binder 707 (PC/RS232) 7-pole circular fem. connector type Binder 712 (connection Master/Slave) L-LAS-LT-80-HS-SL: 8-pole circular fem. connector type Binder 712 (Power) 7-pole circular fem. connector type Binder 712 (connection Master/Slave)	
Connecting cables	connection to PC (Master): 1x cab-las4/PC (-w) or cab-las4/USB (-w) or SI-RS232/Ethernet-4 connection to PLC (each Master and Slave): 2x cab-las8/SPS or cab-las8/SPS-w connection Master with Slave: 1x cab-las7-male or cab-las7-male-w	
Teach/Reset button	for set point teaching or for reset of maximum values via input IN1	
LED display	LED red (+) : Measuring value > upper tolerance threshold LED green : Measuring value within tolerance window LED red (-) : Measuring value < lower tolerance threshold LED yellow : for sensor adjustment (multifunctional)	
EMC test acc. to	DIN EN 60947-5-2	
Scan frequency	max. 600 Hz	
Max. switching current	100 mA, short-circuit proof	
Interface	RS232, parameterisable under Windows®	
Output polarity	bright-/dark-switching, can be switched under Windows®	

Dimensions

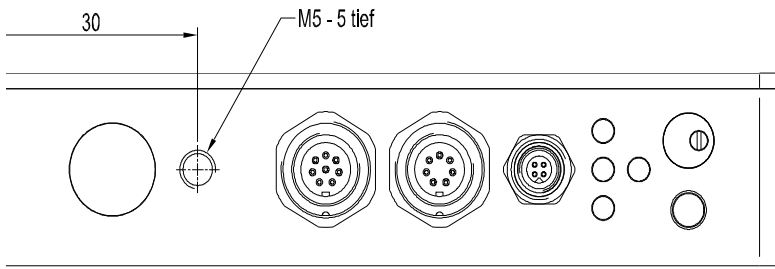

L-LAS-LT-80-HS-MA
 L-LAS-LT-80-HS-MA-4/20
 L-LAS-LT-80-HS-SL

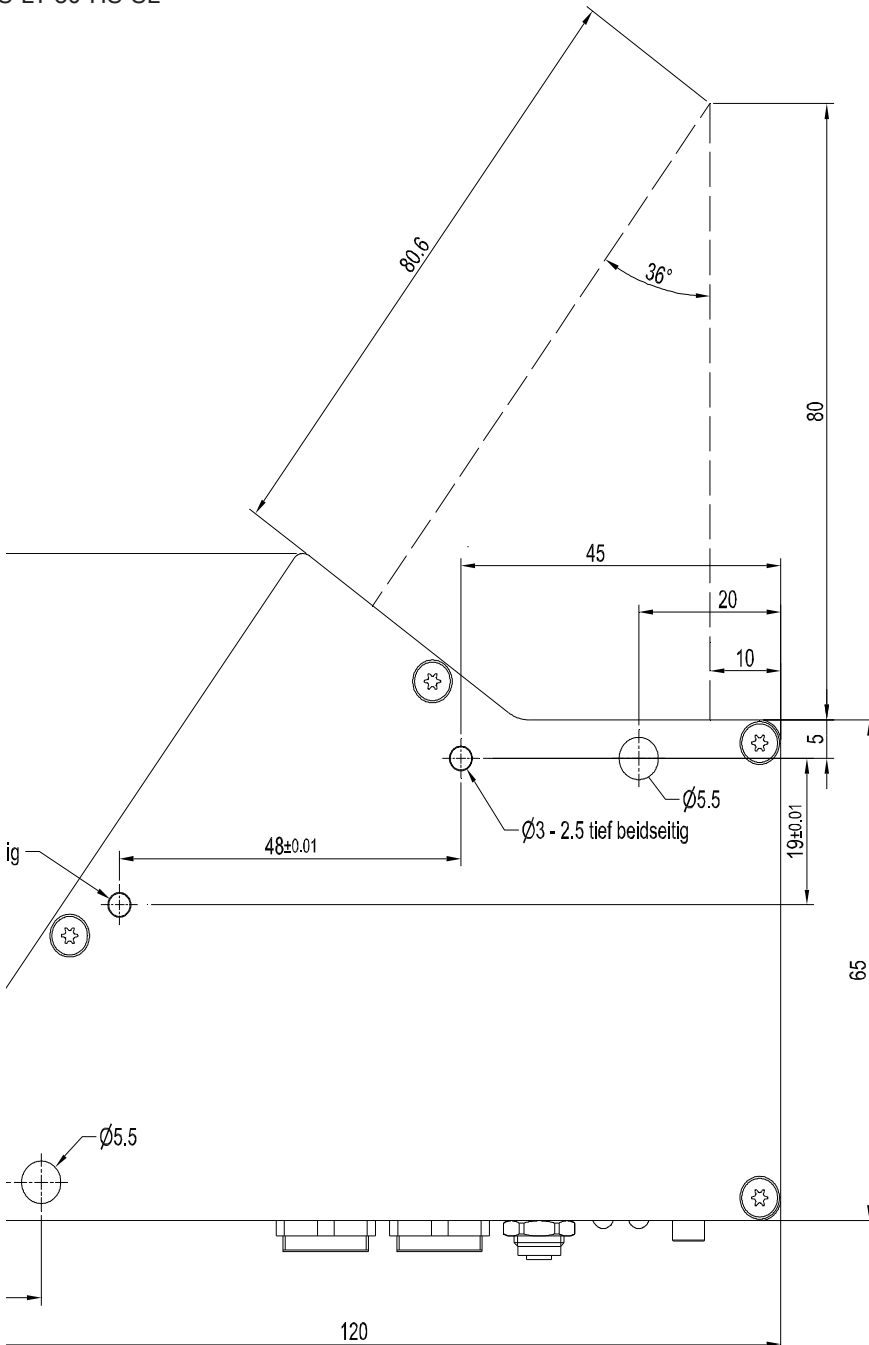

All dimensions in mm



Beam Path

L-LAS-LT-80-HS-MA
L-LAS-LT-80-HS-MA-4/20
L-LAS-LT-80-HS-SL

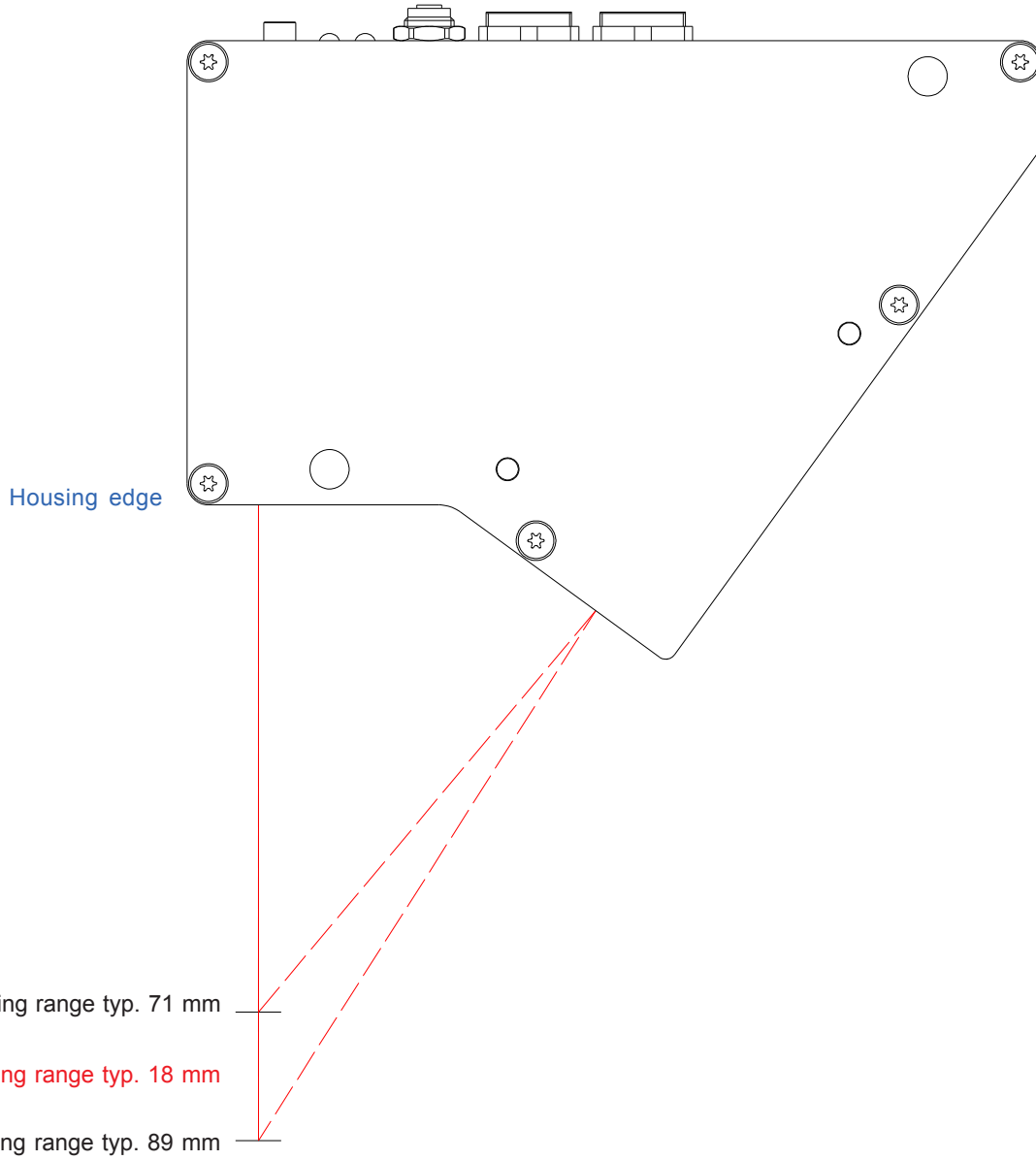



Components of a complete Master/Slave system L-LAS-LT-80-HS-MS:

High speed version with analog voltage output 0...+10V:

- 1x **L-LAS-LT-80-HS-MA** (Master, incl. Windows® software L-LAS-LT-MS-Scope)
- 1x **L-LAS-LT-80-HS-SL** (Slave)
- 1x **cab-las7-male-...** (Connecting cable, connection of Master to Slave)
- 2x **cab-las8/SPS-...** (Connecting cable to PLC, necessary for each Master and Slave)
- 1x **cab-las4/PC-...** (Connecting cable to PC via RS232 interface, necessary for Master only)
- alternative: 1x **cab-las4/USB-...** (Connecting cable to PC via USB interface, necessary for Master only)
- alternative: 1x **SI-RS232/Ethernet-4-...** (Connecting cable to PC via Ethernet interface, necessary for Master only)

High speed version with analog current output 4...20mA:

- 1x **L-LAS-LT-80-HS-MA-4/20** (Master, incl. Windows® software L-LAS-LT-MS-Scope)
- 1x **L-LAS-LT-80-HS-SL** (Slave)
- 1x **cab-las7-male-...** (Connecting cable, connection of Master to Slave)
- 2x **cab-las8/SPS-...** (Connecting cable to PLC, necessary for each Master and Slave)
- 1x **cab-las4/PC-...** (Connecting cable to PC via RS232 interface, necessary for Master only)
- alternative: 1x **cab-las4/USB-...** (Connecting cable to PC via USB interface, necessary for Master only)
- alternative: 1x **SI-RS232/Ethernet-4-...** (Connecting cable to PC via Ethernet interface, necessary for Master only)

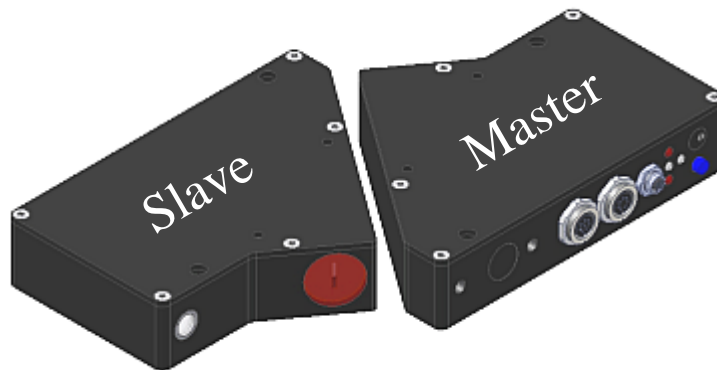

Connection Scheme

Connection scheme for a L-LAS-LT-... MS system

(by way of example L-LAS-LT-55-MS)

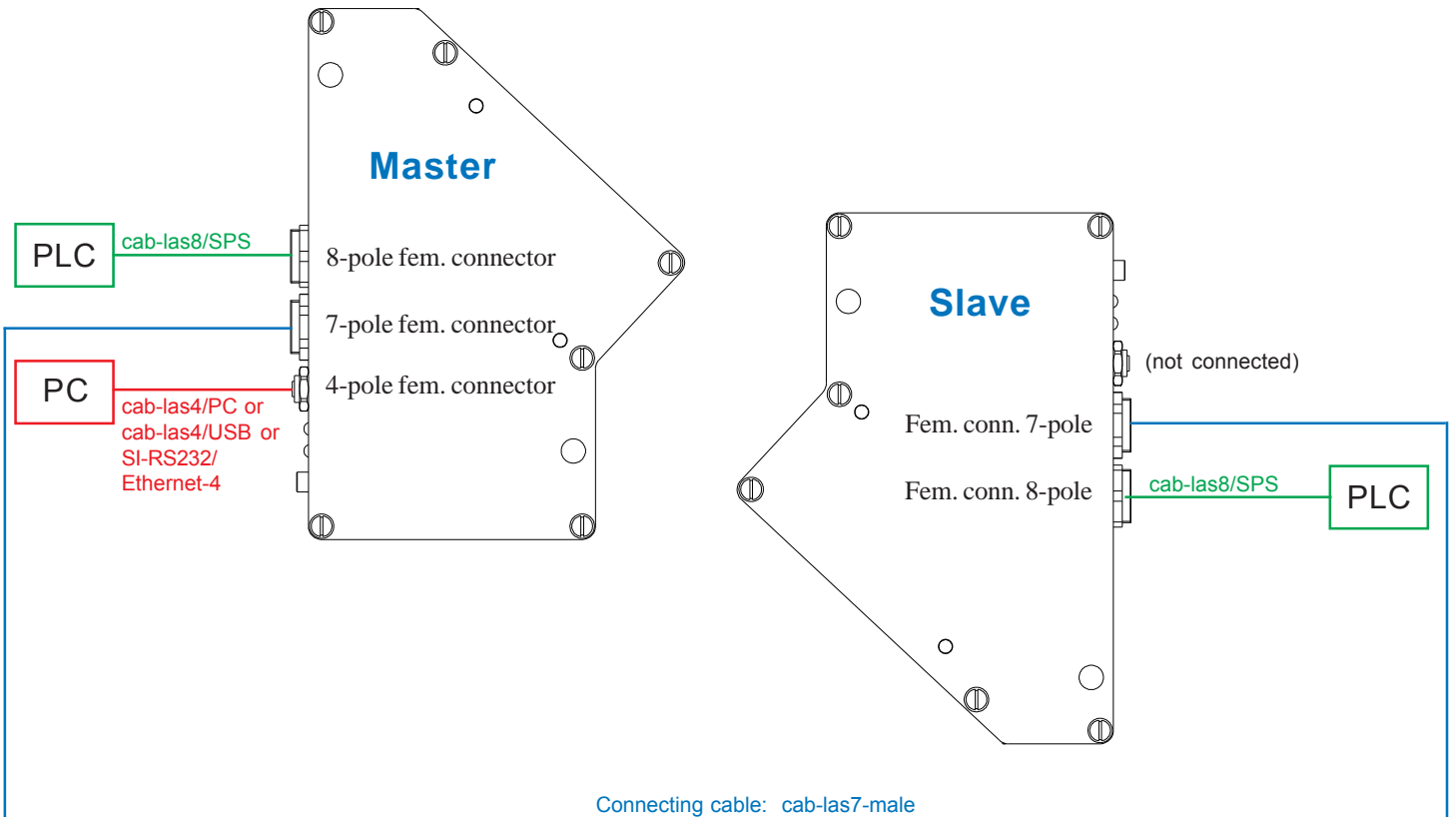
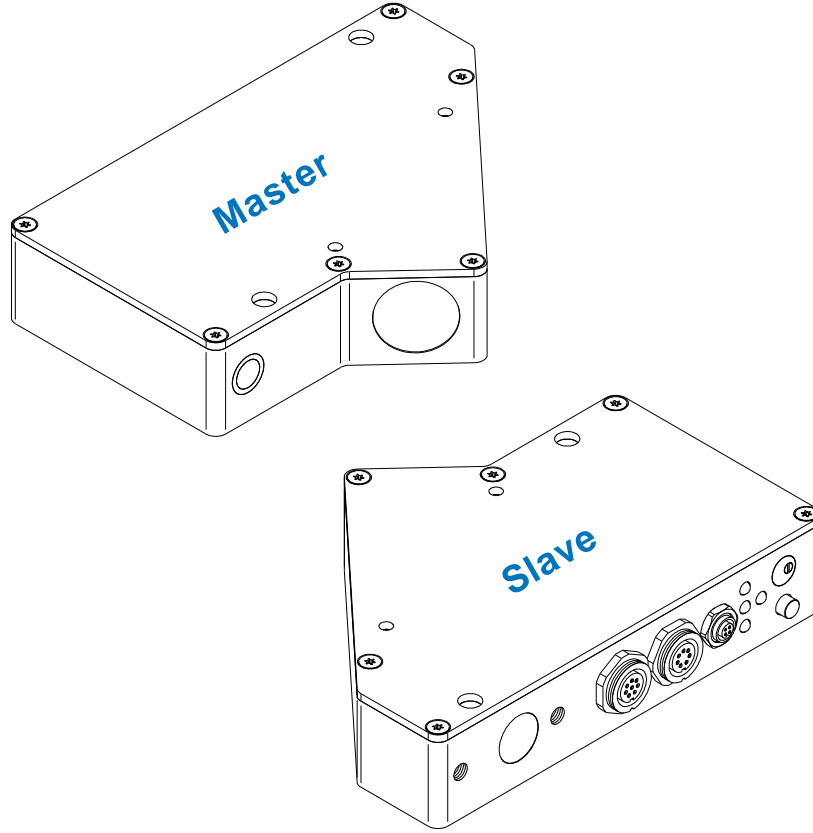



Connector Assignment

Connector assignment of Master L-LAS-LT-...-MA or L-LAS-LT-...-MA -4/20:

Connection to PLC/Power:

8-pole fem. connector Binder Series 712

Pin:	Color:	Assignment:
1	white	GND (0V)
2	brown	+24VDC ($\pm 10\%$)
3	green	IN0 (EXT TRIGGER)
4	yellow	IN1 (TEACH/RESET)
5	grey	OUT0 (-)
6	pink	OUT1 (+)
7	blue	OUT2 (OK)
8	red	ANA (voltage 0 ... +10V) (optional: current 4 ... 20mA)

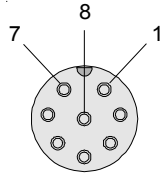

Connection Master/Slave (SPI):

7-pole fem. connector Binder Series 712

Pin:	Assignment:
1	GND (0V)
2	+3.3VDC
3	SS
4	MISO
5	MOSI
6	SCLK
7	+3.3VDC

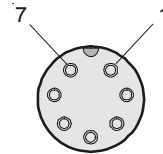

Connecting cable:

cab-las8/SPS-(length) or
cab-las8/SPS-w-(length) (right-angle type)
(standard length 2m)

Connecting cable:

cab-las7-male-(length)
cab-las7-male-w-(length) (right-angle type) VAR. 1
cab-las7-male-w-(length) (right-angle type) VAR. 2
cab-las7-male-w-(length) (right-angle type) VAR. 3
(standard length 1m)

Connection to PC:

4-pole fem. connector Binder Series 707

Pin: Assignment:

Pin:	Assignment:
1	+24VDC (+Ub, OUT)
2	GND (0V)
3	Rx0
4	Tx0

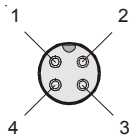

Connection via RS232 interface at the PC:

Connecting cable:

cab-las4/PC-(length)
cab-las4/PC-w-(length) (right-angle type)
(standard length 2m)

alternative:

Connection via USB interface at the PC:

Connecting cable (incl. driver software):

cab-las4/USB-(length)
cab-las4/USB-w-(length) (right-angle type)
(standard length 2m)

alternative:

Connection to local network via Ethernet bus:

Adapter (based on Lantronix XPortModul):

SI-RS232/Ethernet-4-(length)
(standard length 2m)





Connector Assignment

Connector assignment of Slave L-LAS-LT-...-SL:

Connection to Power:

8-pole fem. connector Binder Series 712

Pin:	Color:	Assignment:
1	white	GND (0V)
2	brown	+24VDC ($\pm 10\%$)
3	green	not used
4	yellow	not used
5	grey	not used
6	pink	not used
7	blue	not used
8	red	not used

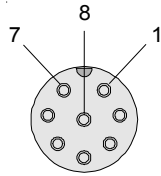

Connecting cable:

[cab-las8/SPS-\(length\)](#) or

[cab-las8/SPS-w-\(length\)](#) (right-angle type)

(standard length 2m)

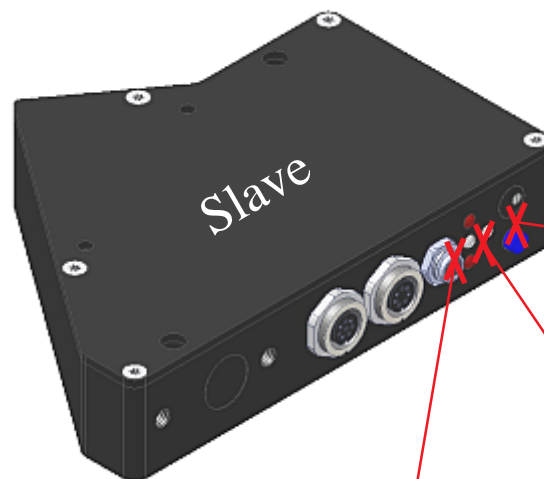

Potentiometer and teach button at the Slave are inactive.

LED display at the Slave is inactive.

Attention:

4-pole connector at the Slave is inactive. Please use the RS232/USB interface at the Master!



Connecting Cables

Connection L-LAS-LT-...-MA (or L-LAS-LT-...-MA-4/20) to PLC:
 Connection L-LAS-LT-...-SL to PLC:

Available connecting cables:

cab-las8/SPS-(length) or
cab-las8/SPS-w-(length)
 (standard length: 2m)

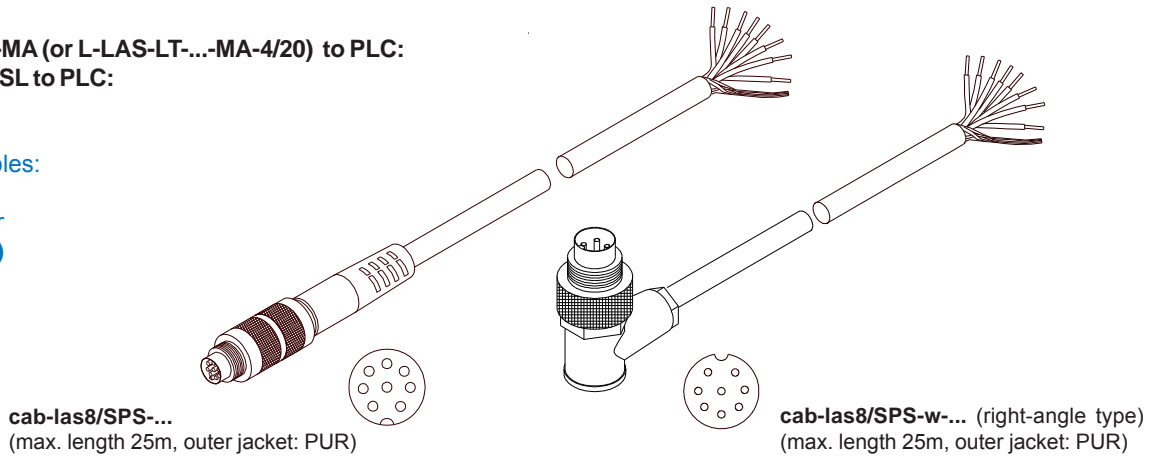

Connection L-LAS-LT-...-MA to L-LAS-LT-...-SL:
 Connection L-LAS-LT-...-MA-4/20 to L-LAS-LT-...-SL:

Available connecting cables:

cab-las7-male-(length)
cab-las7-male-w-(length) VAR. 1
cab-las7-male-w-(length) VAR. 2
cab-las7-male-w-(length) VAR. 3
 (standard length: 1m)

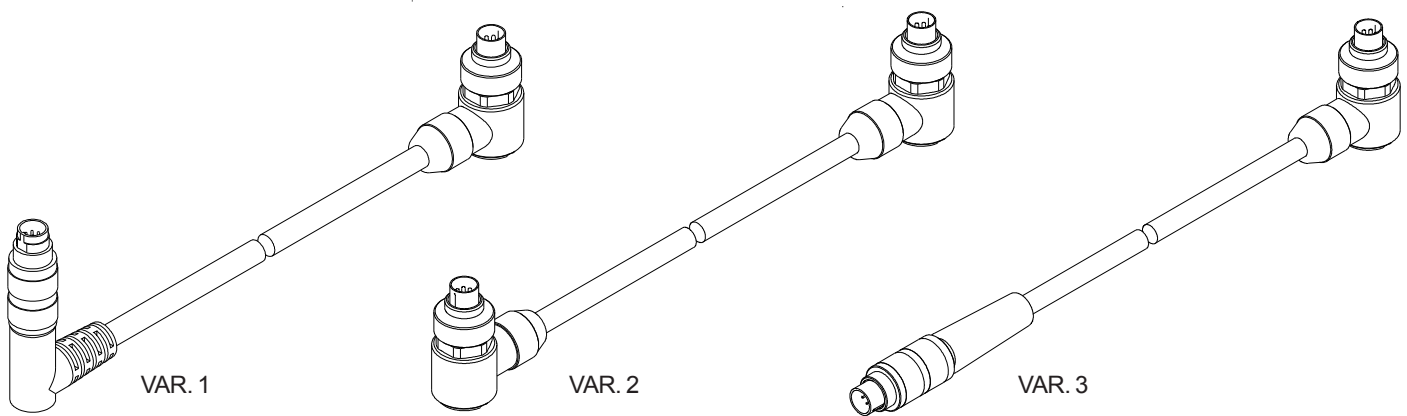
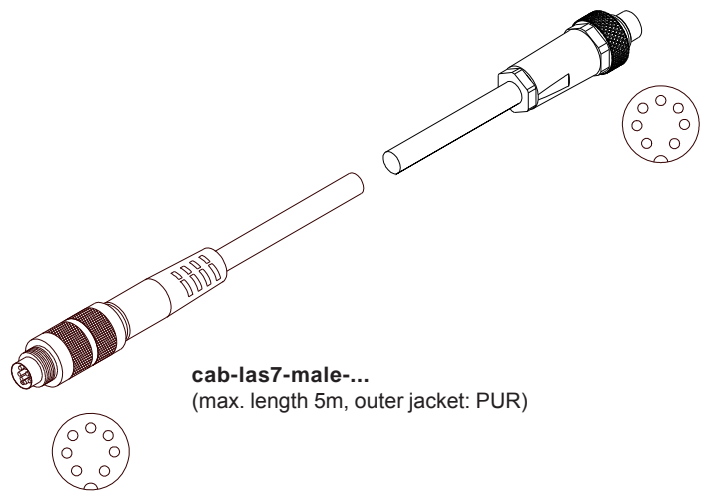

cab-las7-male-w-... VAR. 1
(right-angle type)
 (max. length 5m, outer jacket: PUR)

cab-las7-male-w-... VAR. 2
(right-angle type)
 (max. length 5m, outer jacket: PUR)

cab-las7-male-w-... VAR. 3
(right-angle type)
 (max. length 5m, outer jacket: PUR)



Connecting Cables

Connection L-LAS-LT-...-MA to PC
 Connection L-LAS-LT-...-MA-4/20 to PC:
 via **RS232 interface**

Available connecting cables:

cab-las4/PC-(length) or
cab-las4/PC-w-(length)
 (standard length: 2m)

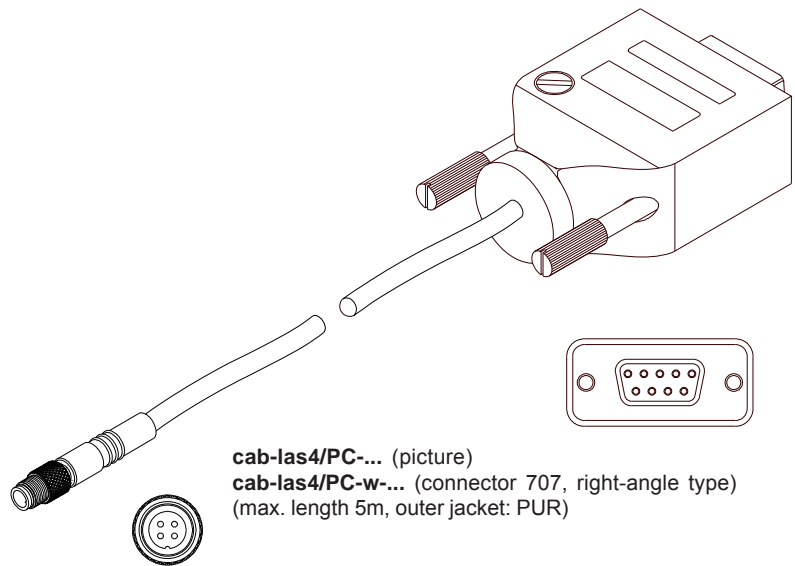

cab-las4/PC-... (picture)
cab-las4/PC-w-... (connector 707, right-angle type)
 (max. length 5m, outer jacket: PUR)

Alternative:
 Connection L-LAS-LT-...-MA to PC
 Connection L-LAS-LT-...-MA-4/20 to PC:
 via **USB interface**

Available connecting cables (incl. driver software):

cab-las4/USB-(length) or
cab-las4/USB-w-(length)
 (standard length: 2m)

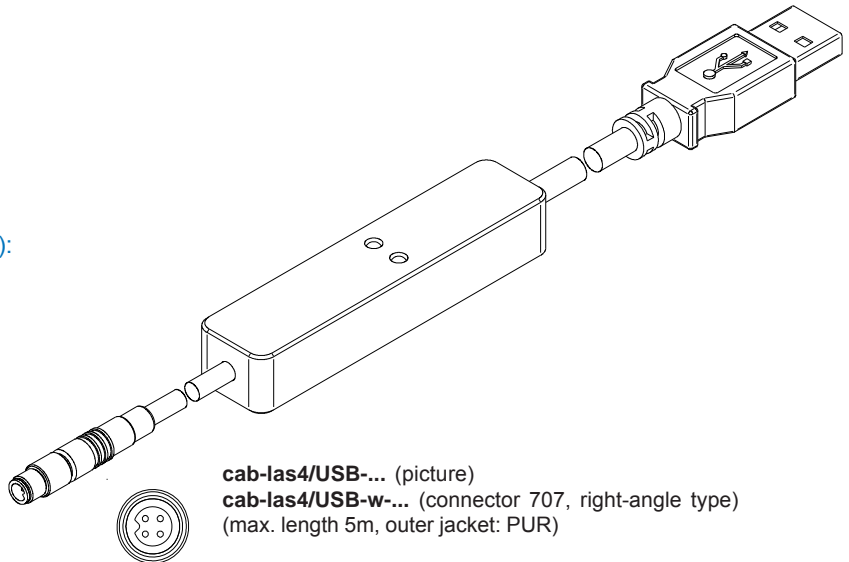

cab-las4/USB-... (picture)
cab-las4/USB-w-... (connector 707, right-angle type)
 (max. length 5m, outer jacket: PUR)

Alternativee:

Anschluss L-LAS-LT-...-MA to a local network:
 Anschluss L-LAS-LT-...-MA-4/20 to a local network:
 via **Ethernet bus**

Adapter (based on Lantronix XPortModul):

SI-RS232/Ethernet-4-(length)
 (standard length: 2m)

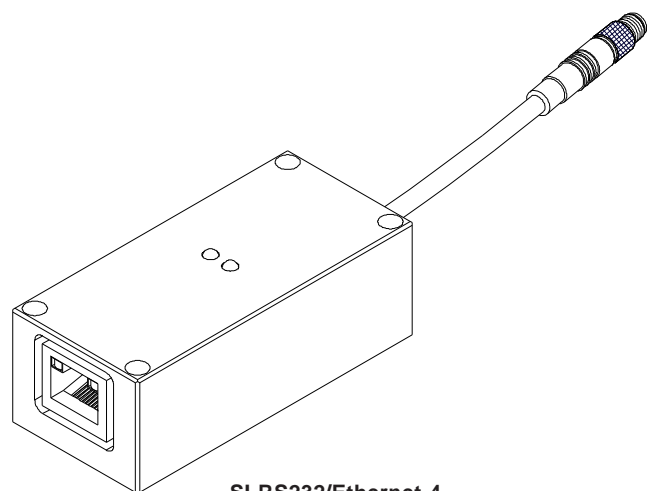

SI-RS232/Ethernet-4-...
 (available lengths: 0,5m, 1m, or 2m,
 outer jacket: PUR)

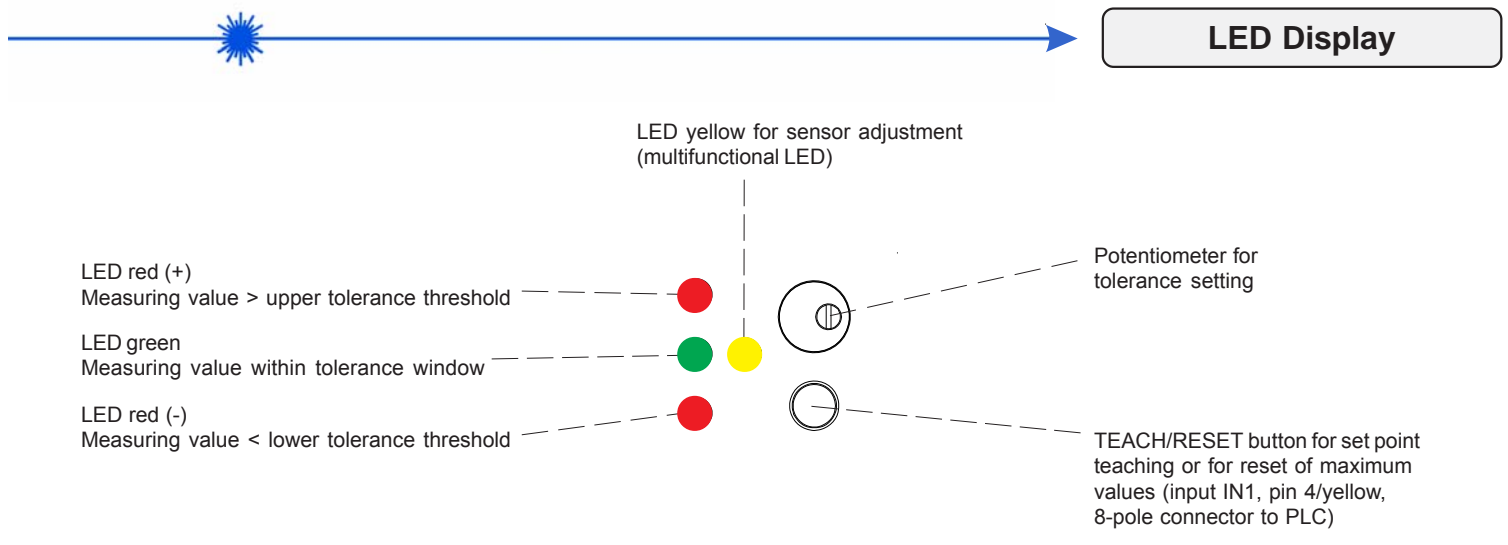

LED display is only active at the Master:

L-LAS-LT-80-HS-MA
L-LAS-LT-80-HS-MA-4/20



Laser Warning

The laser line sensors of L-LAS-LT Series comply with laser class 2 according to EN 60825-1. The use of these laser transmitters therefore requires no additional protective measures.

The laser line sensors of L-LAS-LT Series are supplied with a laser warning label.



LASER RADIATION

DO NOT STARE INTO THE BEAM

CLASS II LASER PRODUCT

Parameterization
Windows® software L-LAS-LT-MS-Scope:

The L-LAS-LT-...-MS sensor can be easily parameterised with the Windows® user interface. For this purpose the sensor is connected to the PC with the serial interface cable cab-las4/PC (or with USB cable cab-las4/USB or with Ethernet adapter SI-RS232/Ethernet-4). When parameterisation is finished, the PC can be disconnected again.

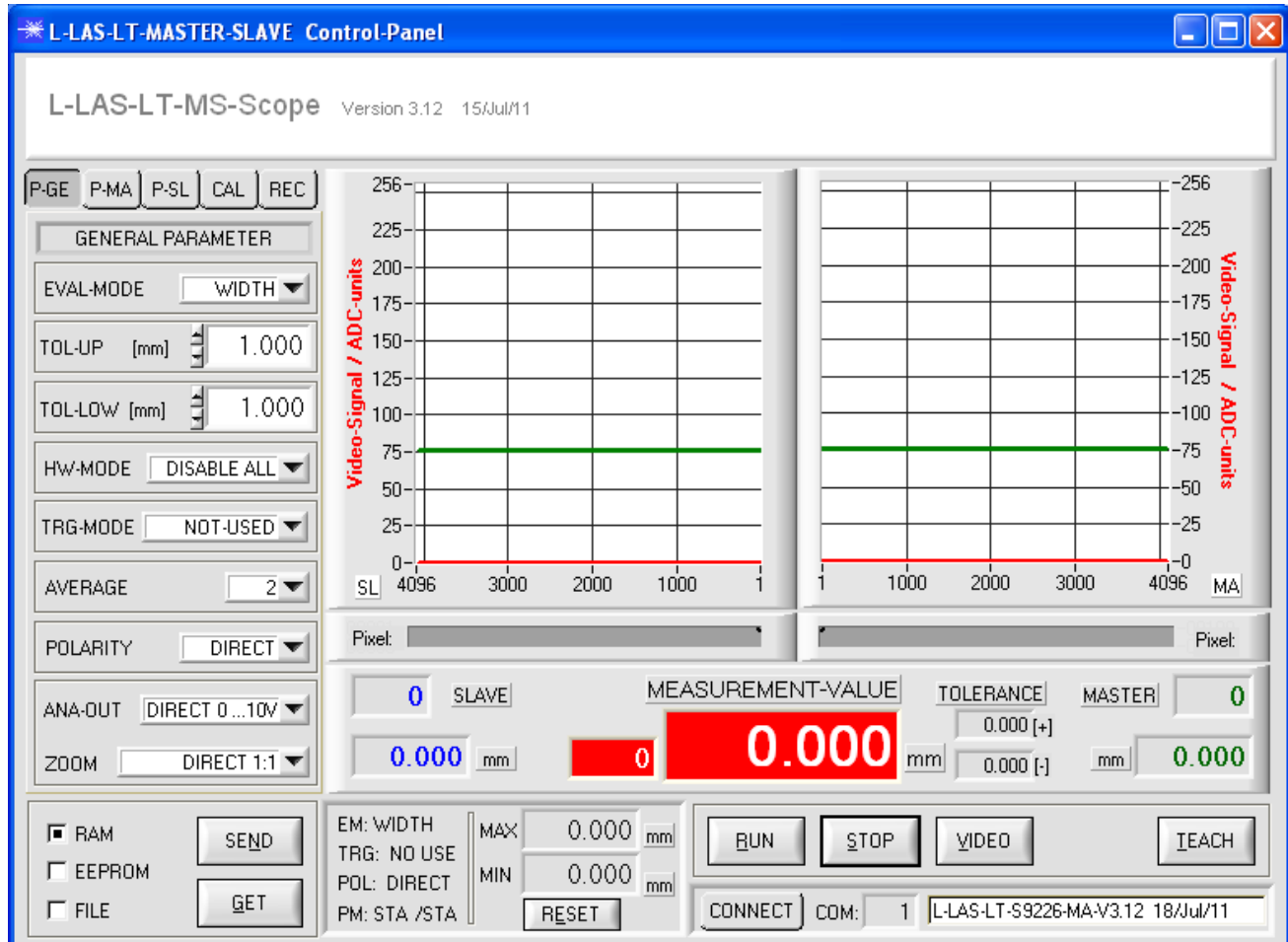
Windows® user interface:

With the help of the L-LAS-LT-MS-Scope software the following settings can be made at the sensor:

- Setting of laser power and type of automatic power correction
- Polarity of digital outputs
- Different evaluation modes
- Start of the teach process by software button
- Setting of tolerance ranges for monitoring the measured value

Furthermore, various numerical and graphical measured quantities can be visualized with the L-LAS-LT-MS-Scope software. For example, the raw data of the CCD line sensor can be displayed graphically and numerically.



Mounting

Mounting plate C-MOUNT-LT-80

(please order separately)

suitable for Master/Slave line sensor
L-LAS-LT-80-HS-MA (Master) and
L-LAS-LT-80-HS-SL (Slave)

- Distance Master and Slave (optical axis) adjustable in 3 mm steps (symmetrically each side 1.5 mm): from min. 116.8 mm to max. 161.8 mm
- Sturdy material (aluminum, anodized in black)

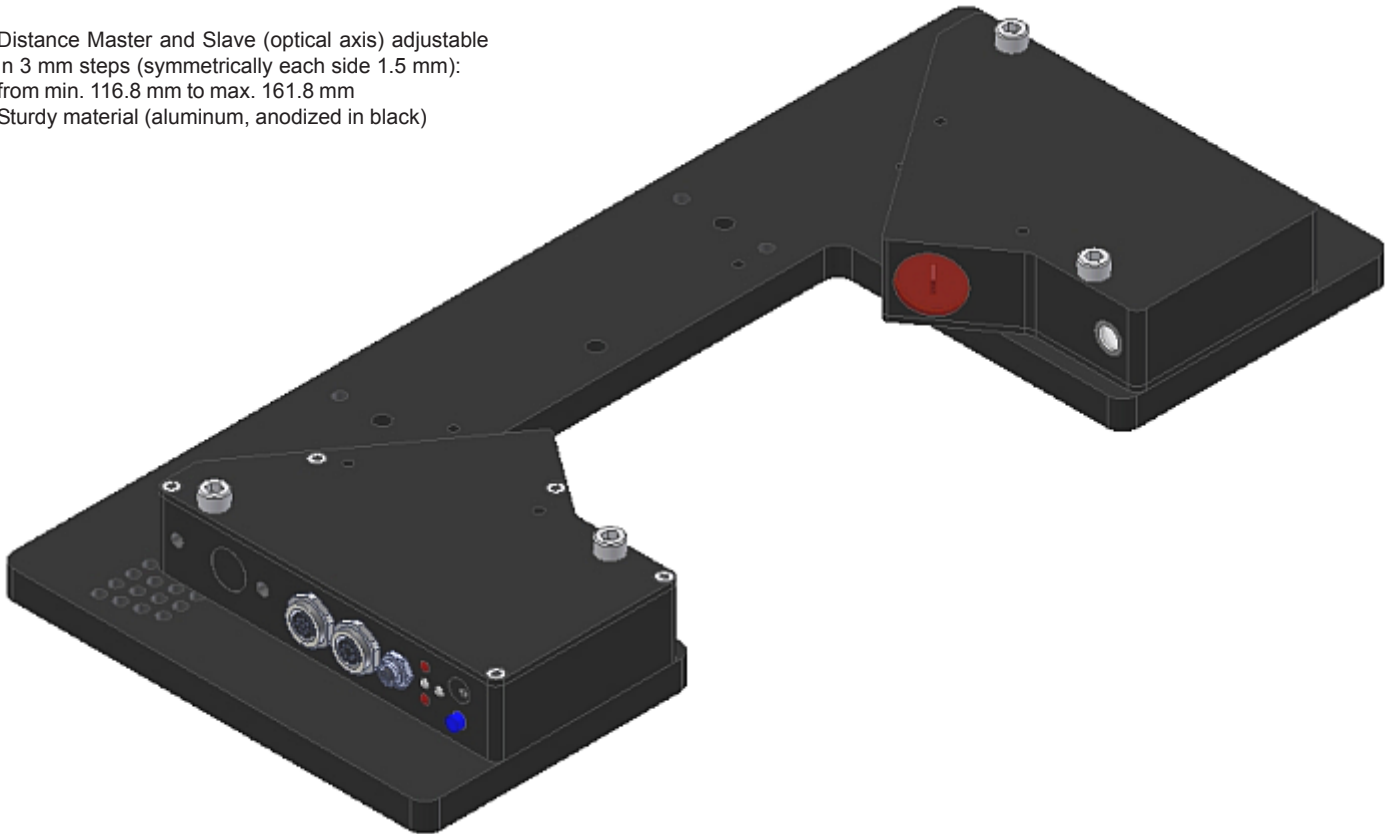

Adjustment positions (cf. drawing on the next page):
E = Distance Master/Slave (optical axis) in mm

Adjustment position	A	B	C	D	E
1.	160	0	20	10	116.8
2.	163	0	23	16	119.8
3.	166	0	26	22	122.8
4.	169	0	29	28	125.8
5.	172	0	32	10	128.8
6.	175	0	35	16	131.8
7.	178	0	38	22	134.8
8.	181	1	41	28	137.8
9.	184	4	44	10	140.8
10.	187	7	47	16	143.8
11.	190	10	50	22	146.8
12.	193	13	53	28	149.8
13.	196	16	56	10	152.8
14.	199	19	59	16	155.8
15.	202	22	62	22	158.8
16.	205	25	65	28	161.8

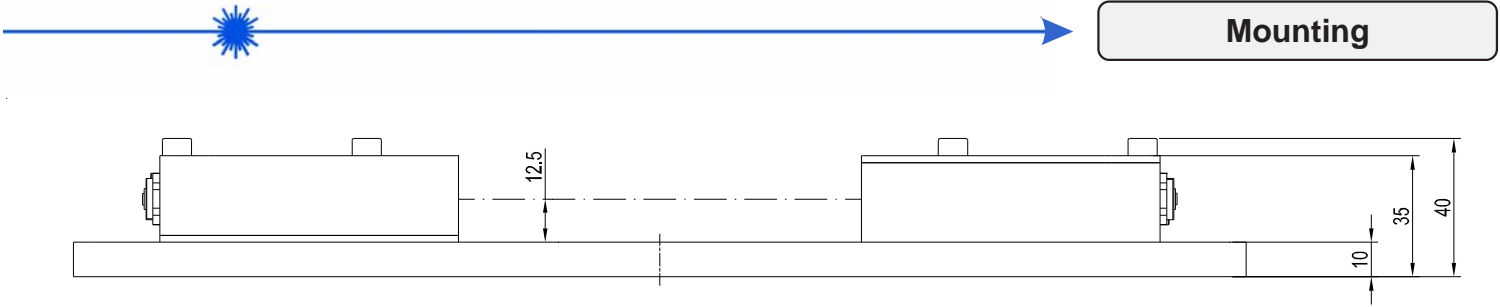

**Mounting plate
C-MOUNT-LT-80**

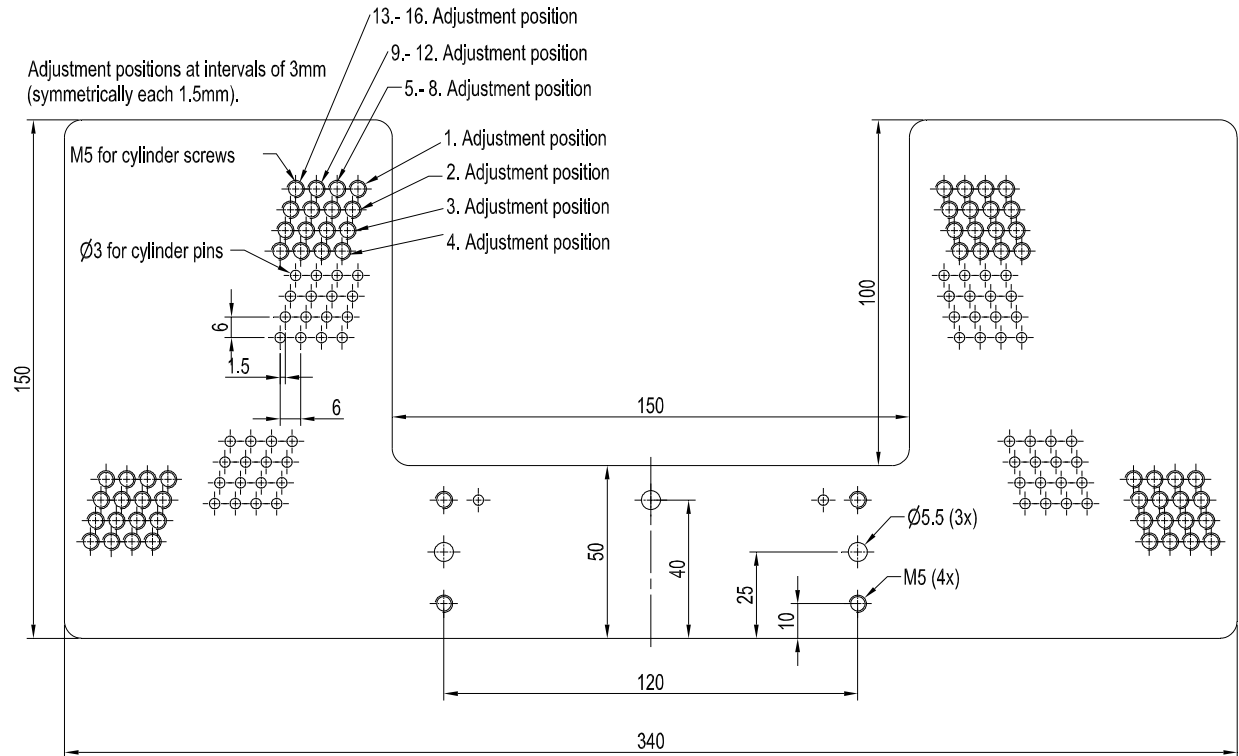
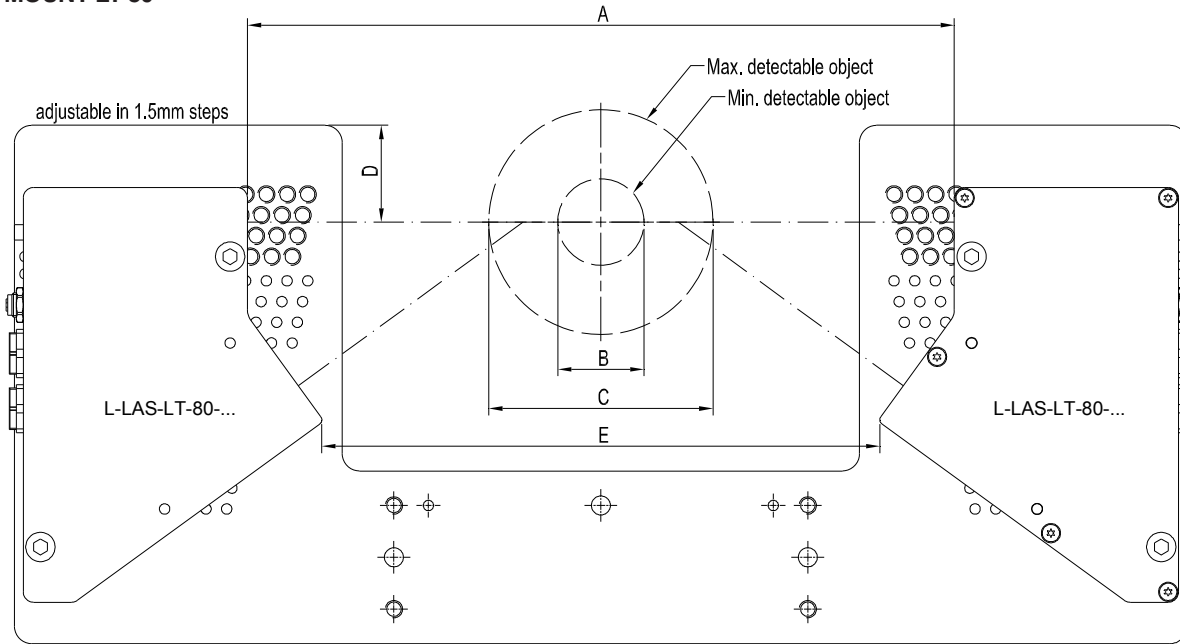

(All dimensions in mm)