

# L-LAS Series

## ▶ L-LAS-RL-20-...-CL

- Various optical fibers available  
(W=white light filter, R=red light filter, B=blue light filter, UV=black filter)
- Ring illumination with 9 LED
- Reference distance 55 mm
- Working distance 55 mm ± 5 mm
- Working range typ. 20 mm
- Resolution typ. 20 µm
- Minimal detectable object typ. 0.1 mm
- CCD line detector, 512 pixel (4096 subpixel)
- External TEACH/RESET push-button
- RS232 interface (USB or Ethernet adapter available)
- Switching state indication via 5 yellow LED
- 2 digital inputs (IN0, IN1), 3 digital outputs (OUT0 .. OUT2)
- 1 analog output (voltage 0...+10V or current 4...20mA)
- Detection of position or width of the measuring object in reflected light operation



Picture: L-LAS-RL-20-W-CL



## Design

### Product name:

- L-LAS-RL-20-W-CL** (with white light filter)
  - L-LAS-RL-20-R-CL** (with red light filter)
  - L-LAS-RL-20-B-CL** (with blue light filter)
  - L-LAS-RL-20-UV-CL** (with UV filter)
- incl. Windows® PC software L-LAS-RL-Scope

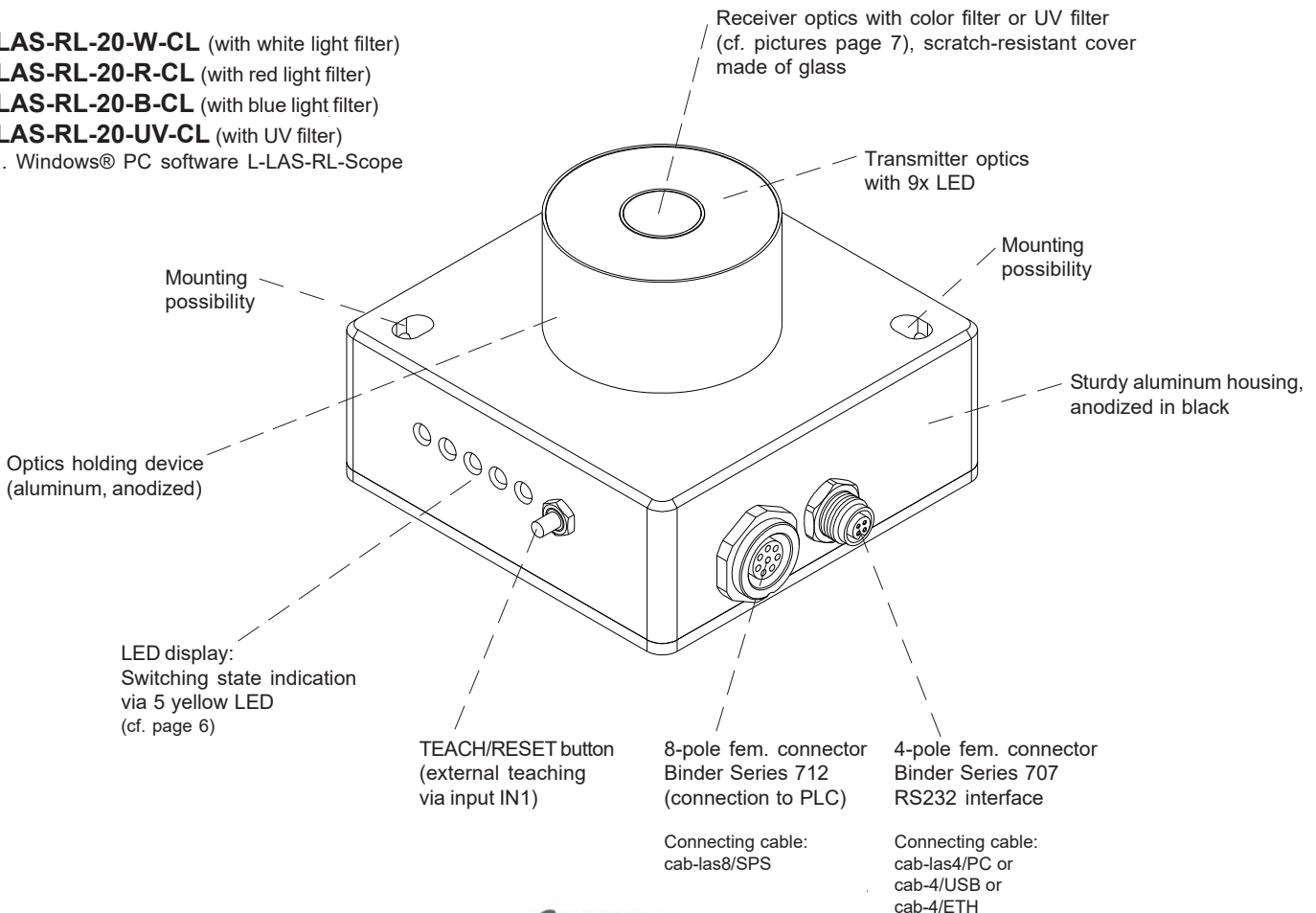



**Technical Data**

| Model                              | L-LAS-RL-20-...-CL   |
|------------------------------------|--|
| Reference distance                 | 55 mm  |
| Working distance                   | 55 mm ± 5 mm   |
| Working range                      | typ. 20 mm   |
| Resolution                         | typ. 20 µm   |
| Reproducibility                    | typ. ± 60 µm   |
| Min. detectable object             | typ. 0.1 mm  |
| Light source                       | L-LAS-RL-20-W-CL: Ring illumination comprising 9x white light LED, diffuse<br>L-LAS-RL-20-R-CL: Ring illumination comprising 9x red light LED, diffuse<br>L-LAS-RL-20-B-CL: Ring illumination comprising 9x blue light LED, diffuse<br>L-LAS-RL-20-UV-CL: Ring illumination comprising 9x UV-LED |
| Optical filter                     | L-LAS-RL-20-W-CL: white light filter<br>L-LAS-RL-20-B-CL: blue light filter<br>L-LAS-RL-20-R-CL: red light filter<br>L-LAS-RL-20-UV: b-CLackfilter   |
| Optical diffusor                   | for L-LAS-RL-20-W-CL, L-LAS-RL-20-R-CL, and L-LAS-RL-20-B-CL: Surface diffusor screen  |
| Digital outputs 3x (OUT0 ... OUT2) | pnp bright-switching/npn dark-switching or pnp dark-switching/npn bright-switching, adjustable under Windows®, 100 mA, short-circuit proof   |
| Analog output 1x                   | adjustable under Windows®: voltage U <sub>OUT</sub> (0 ... +10V) or current I <sub>OUT</sub> (4 ... 20mA)  |
| Digital inputs 2x (IN0, IN1)       | input voltage +Ub/0V, with protective circuit, IN0: Teach Extern, IN1: Teach/Reset   |
| Output polarity                    | bright/dark-switching, can be switched under Windows®  |
| Voltage supply                     | +24 VDC (± 10%)  |
| Current consumption                | < 220 mA   |
| Enclosure rating                   | electronics: IP64, optics: IP67  |
| Sensitivity setting                | adjustable under Windows® via PC   |
| Ambient light                      | up to 3000 Lux   |
| Intensity correction               | adjustable under Windows® via PC   |
| Operating temperature range        | -10°C ... +60°C  |
| Storage temperature range          | -20°C ... +85°C  |
| Housing material                   | aluminum, anodized in black,<br>optics holding device: aluminum, anodized  |
| Housing dimensions                 | LxWxH approx. 65 mm x 65 mm x 45.3 mm (incl. optics holding device Ø 34 mm, without connectors)  |
| Type of connector                  | 8-pole circular female connector type Binder Series 712 (PLC/Power),<br>4-pole circular female connector type Binder Series 707 (PC/RS232)   |
| Connecting cables                  | connection to PC: cab-las4/PC, cab-4/USB or cab-4/ETH<br>connection to PLC: cab-las8/SPS   |
| LED display                        | LED yellow (-) : Measuring value < lower tolerance threshold<br>LED yellow (OK) : Measuring value within tolerance window<br>LED yellow (+) : Measuring value > upper tolerance threshold (middle)<br>LED yellow : Multifunctional LED<br>LED yellow : Power LED                                 |
| EMC test acc. to                   | DIN EN 60947-5-2   |
| Scan frequency                     | max. 750 Hz  |
| Interface                          | RS232, parameterizable under Windows®  |

Dimensions

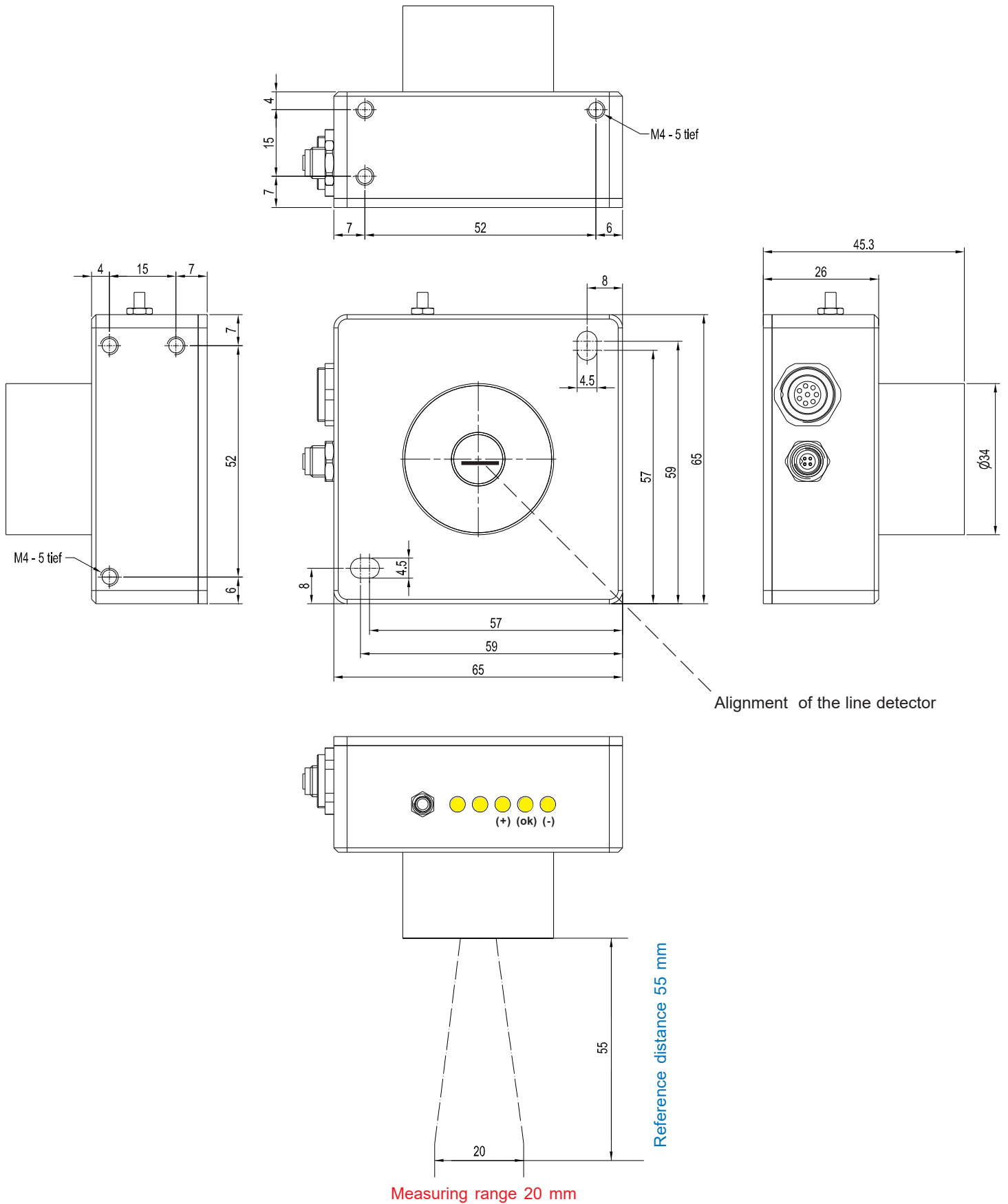

Measuring range 20 mm

Reference distance 55 mm

All dimensions in mm



**Variants**

**Available variants:**





**Connector Assignment**

**Connection to PLC:**

**8-pole fem. connector Binder Series 712**

| Pin: | Color: | Assignment:                                      |
|------|--------|--|
| 1    | white  | GND (0V)   |
| 2    | brown  | +24VDC (±10%)                                    |
| 3    | green  | IN0 (EXT TRIGGER)                                |
| 4    | yellow | IN1 (TEACH / RESET)                              |
| 5    | grey   | OUT0 (-)   |
| 6    | pink   | OUT1 (+)   |
| 7    | blue   | OUT2 (ok)  |
| 8    | red    | Analog (0...+10V) or I <sub>OUT</sub> (4...20mA) |

Connecting cable:  
 cab-las8/SPS-(length)  
 cab-las8/SPS-w-(length) (angle type, 90°)  
 (standard length 2m)

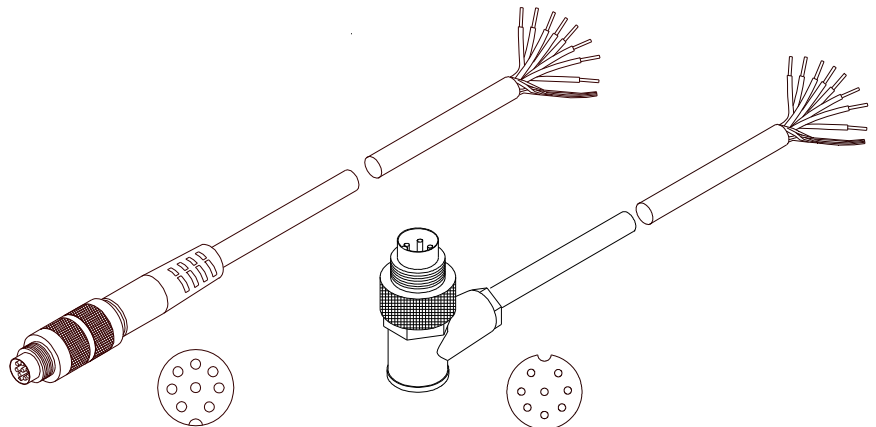

cab-las8/SPS-...  
 (max. length 25m, outer jacket: PUR)

cab-las8/SPS-w-...  
 (max. length 25m, outer jacket: PUR)

**Connection to PC:**

**4-pole fem. connector Binder Series 707**

| Pin: | Assignment:       |
|------|-------------------|
| 1    | +24VDC (+Ub, OUT) |
| 2    | GND (0V)          |
| 3    | RxD               |
| 4    | TxD               |

**Connection via RS232 interface at the PC:**

Connecting cable:  
 cab-las4/PC-(length)  
 cab-las4/PC-w-(length) (angle type 90°)  
 (standard length 2m)

**alternative:**

**Connection via USB interface at the PC:**

Connecting cable (incl. driver software):  
 cab-4/USB-(length)  
 cab-4/USB-w-(length) (angle type 90°)  
 (standard length 2m)

**alternative:**

**Connection to local network via Ethernet bus:**

Adapter (incl. software „SensorFinder“):  
 cab-4/ETH-500  
 (standard length 0.5m)

Optional: External CAT5 cable, e.g.  
 cab-eth/M12D-RJ45-flx-(length)

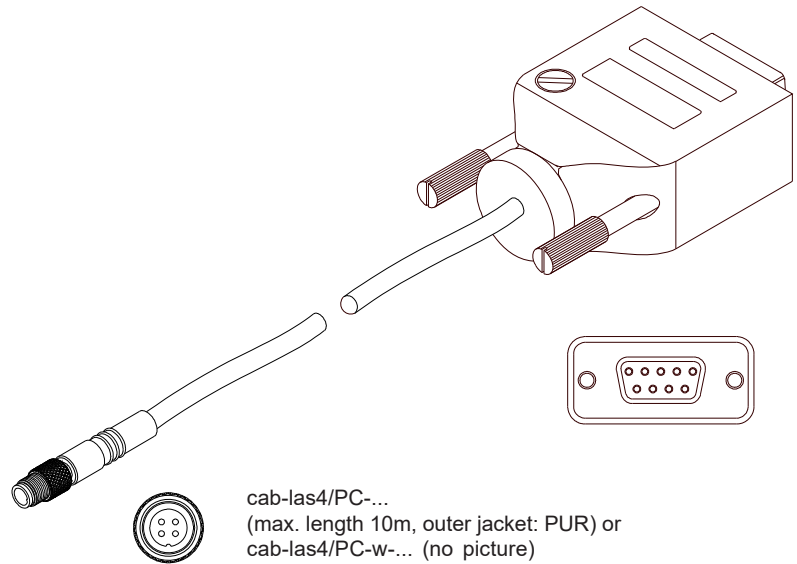

cab-las4/PC-...  
 (max. length 10m, outer jacket: PUR) or  
 cab-las4/PC-w-... (no picture)  
 (max. length 5m, outer jacket: PUR)

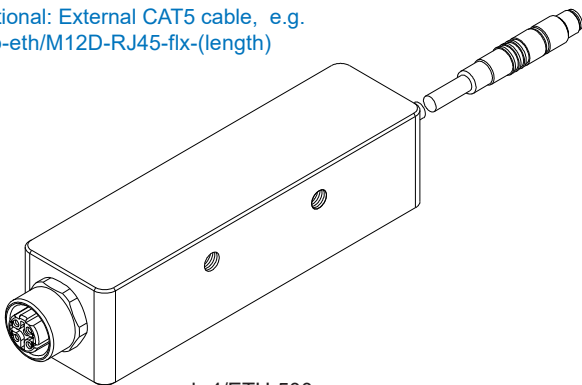

cab-4/ETH-500  
 (length 0.5m, outer jacket: PUR)  
 4-pole M12 fem. conn. (D-coded)  
 for connection of an external  
 CAT5 cable, e.g.  
 cab-eth/M12D-RJ45-flx-(length)

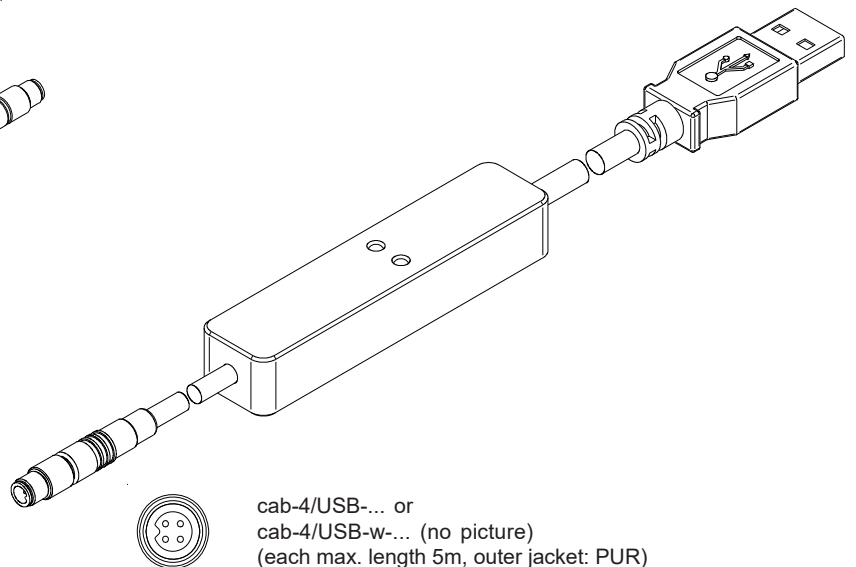

cab-4/USB-... or  
 cab-4/USB-w-... (no picture)  
 (each max. length 5m, outer jacket: PUR)



**Measuring Principle**

**Measuring principle of the L-LAS-RL-20-...-CL:**

The sensors of the L-LAS-RL series are line sensors that operate according to the reflected light (RL) principle. The measuring object is illuminated by means of a ring illumination unit comprising 9 red light LED, blue light LED, or white light LED (followed by an optical diffuser) or 9 UV-LED. The intensity of this ring illumination automatically adjusts itself to the surface properties (light-adaptive setting).

An optics unit reproduces the light that is scattered back from the object surface on a CCD line. A micro-controller then evaluates the intensity information (video signal) coming from the measuring object.

The scan frequency is approx. 750 Hz.  
 Several evaluation modes are available.  
 At an optimal object distance of 55 mm the sensor has a measuring range of approx. 20 mm.  
 The resolution is 20 µm (CCD with 512 pixel, 4096 subpixel).  
 The smallest detectable measuring object is approx. 0.1 mm.

The L-LAS-RL-...-CL sensor can be connected to the PLC by way of an 8-pole circular female connector. A 4-pole circular female connector can be used to connect the sensor to the serial interface of a PC. The sensor can be parameterised with the L-LAS-RL-Scope Windows software.

The L-LAS-RL-...-CL sensor features two digital inputs IN0 (external trigger) and IN1 (teach/reset) and three digital switching outputs OUT0, OUT1, and OUT2 as well as one analog output ( $U_{OUT}$  or  $I_{OUT}$ ). Outputs OUT0 (-), OUT1 (+) and OUT2 (ok) are used to output the actual value / setpoint value comparison (measurement value higher than setpoint range and measurement value lower than setpoint range). The analog output can be preset as voltage output (0...+10V) or as current output (4...20mA), the current measurement value will be sent to the PLC with 12-bit resolution.



**LED Display**

**LED display:**

The current measurement value is visualised by way of three LEDs (red/green/red) at the sensor housing. The switching state that is indicated at the LED display also is applied at the digital outputs OUT0, OUT1, and OUT2.

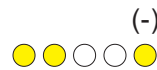
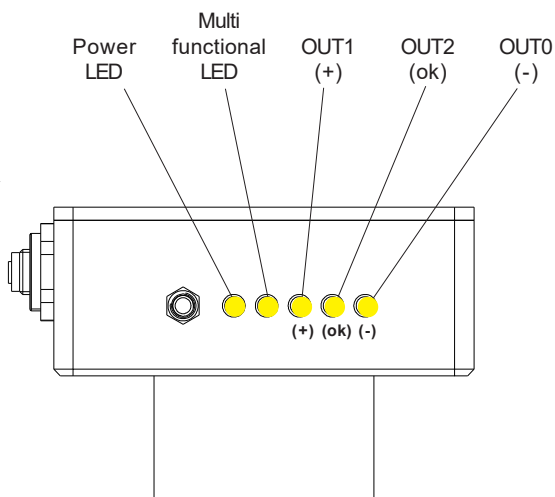

Measuring value < lower tolerance threshold  
 OUT0 (-)

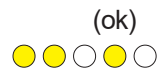

Measuring value within tolerance band  
 OUT2 (ok)



Measuring value > upper tolerance threshold  
 OUT1 (+)



Windows® Software

**Windows® software L-LAS-RL-Scope:**

The L-LAS-RL-... sensor can be easily parameterized with the help of the Windows® user interface. For this purpose the sensor is connected to the PC by way of the cab-las4/PC (or cab-4/USB or cab-4/ETH) interface cable.

When parameterization is finished, the PC can be disconnected again (press STOP button), the sensor system continues to operate with the current parameters in STAND-ALONE mode without a PC.

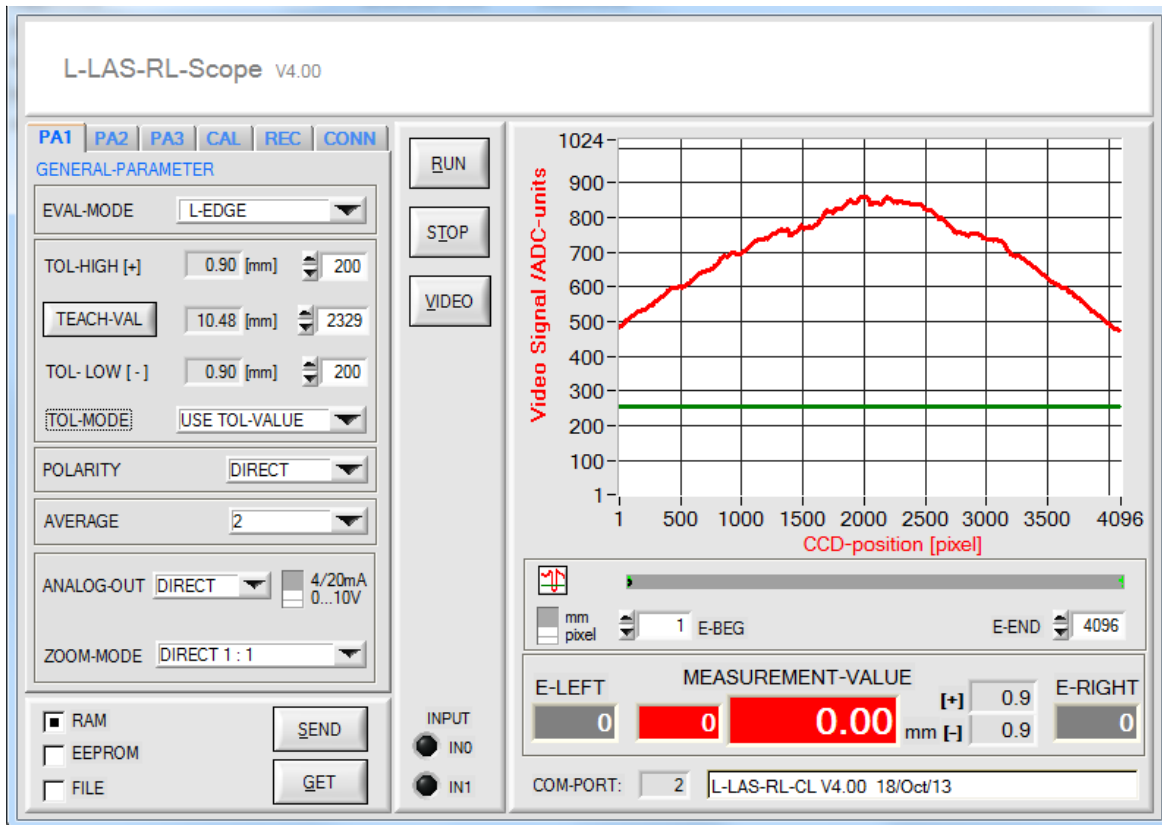



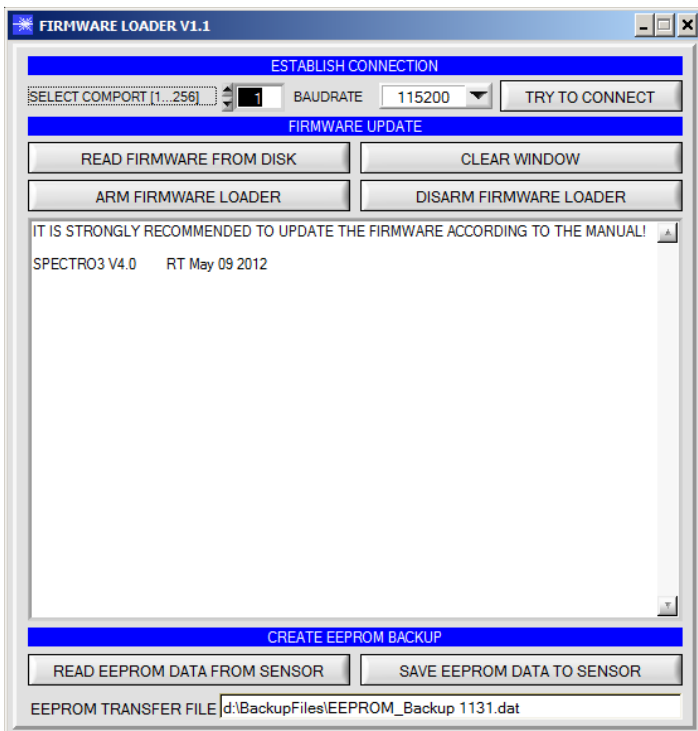

**Firmware Update**
**Firmware update by means of the software „FirmwareLoader“:**

The software „Firmware Loader“ allows the user to perform an automatic firmware update. The update will be carried out through the RS232 interface.

An initialisation file (xxx.ini) and a firmware file (xxx.elf.S) are required for performing a firmware update. These files can be obtained from your supplier. In some cases an additional firmware file for the program memory (xxx.elf.p.S) is also needed, and this file will be automatically provided together with the other two files.

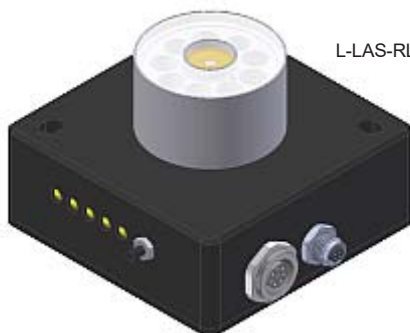

**Variants**
**Available variants:**

L-LAS-RL-20-W-CL

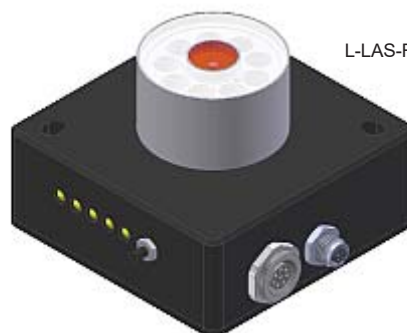

L-LAS-RL-20-R-CL



L-LAS-RL-20-B-CL



L-LAS-RL-20-UV-CL