

FIA Series

► FIA-A-H...

- High reproducibility
- Integrated electronics
- Infrared light beam (IR LED 905 nm)
- High switching frequency (typ. 100 kHz)
- Temperature-compensated
- Analog output (0 ... +5V)
- Blast-air connector
- Scratch-resistant optics
- Enclosure rating IP67
- Compact, sturdy aluminum housing, oil-resistant cable
- Also available with circular connector or tool plug

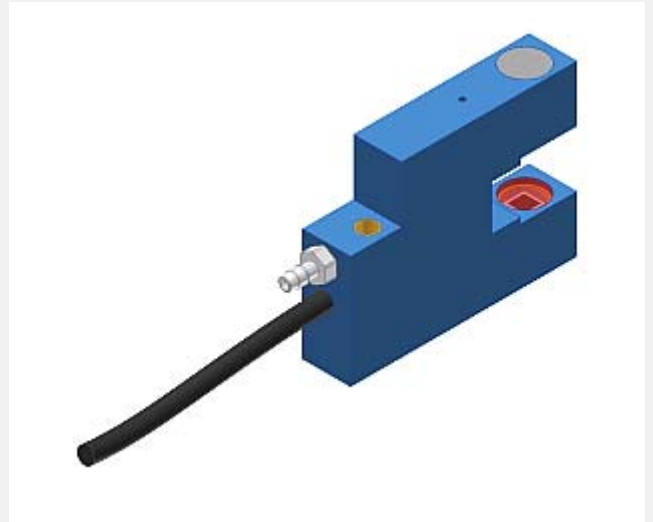

Design

Product name:

FIA-A-H-(aperture)-(fork size)-(length)

FIA-A-H-(aperture)-(fork size)-P-(length) (incl. 8-pole circular connector, s. below)

FIA-A-H-(aperture)-(fork size)-TPN-(length) (incl. tool plug TPN-01, s. below)

Round apertures *d*... (∅ mm):

d0.4	d1.0
d0.6	d1.5
d0.8	d2.0

Rectangular apertures *A*x*B* (mm):

0.2 x 0.5	0.5 x 1
0.2 x 1	0.75 x 2
0.3 x 0.8	0.75 x 3
0.3 x 1	1 x 1
0.3 x 1.5	1 x 1.2
0.3 x 3	1 x 2

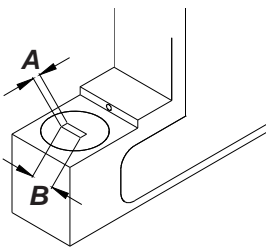

Aluminum housing, anodized in blue

Mounting hole

Blast-air connector

Receiver optics with day light block filter

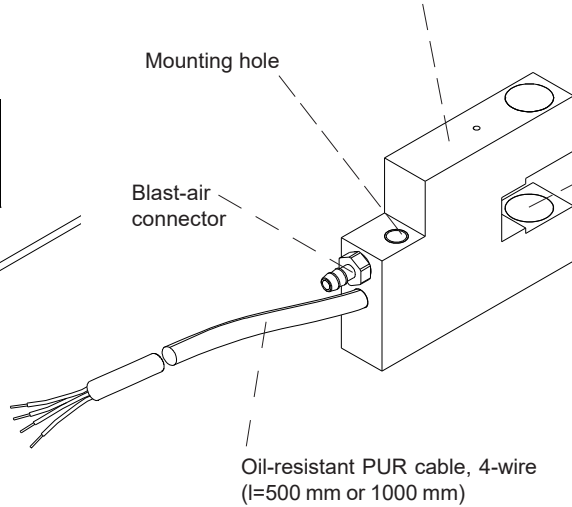

Oil-resistant PUR cable, 4-wire (l=500 mm or 1000 mm)

Fork sizes: (cf. dimensions page 3)

- 10/10** (fork width A=10 mm, fork depth B=10 mm)
- 10/15** (fork width A=10 mm, fork depth B=15 mm)
- 10/20** (fork width A=10 mm, fork depth B=20 mm)
- 10/30** (fork width A=10 mm, fork depth B=30 mm)
- 15/10** (fork width A=15 mm, fork depth B=10 mm)
- 20/10** (fork width A=20 mm, fork depth B=10 mm)
- 20/30** (fork width A=20 mm, fork depth B=30 mm)

Length:

- 500** (cable length = 500 mm)
- 1000** (cable length = 1000 mm)

Also available with 8-pin circular connector or tool plug:

- P** (8-pin circular connector, type Binder 712)
- TPN** (tool plug TPN-01 with 8-pole connector Binder 702)

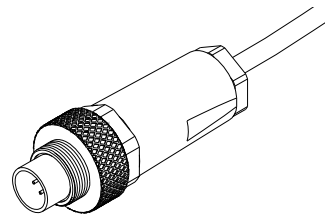

"P"
(circular connector, 8-pole)

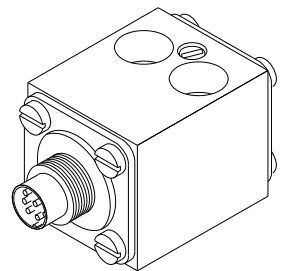

"TPN"
(tool plug TPN-01)



Technical Data

Type	FIA-A-H-...
Transmitter	IR LED: 905 nm
Min. detectable object	typ. 0.05 mm
Reproducibility	typ. 0.2% of measuring range
Optical filter	Day light block filter
Voltage supply	+5VDC
Analog output	0V ... +5V
Band width analog signal	100 kHz (-3dB)
Current consumption	typ. 30 mA
Available apertures	circular apertures (max. Ø 2 mm) or rectangular apertures (max. 2 mm x 1 mm)
Enclosure rating	IP67
Operating temperature range	-20°C ... +50°C
Storage temperature range	-20°C ... +85°C
Housing material	Aluminum, anodized in blue
Housing dimensions	cf. page 3
Cable type	cable intergrated at sensor housing: 4-wire, outer jacket PUR, shielded, length = 500 mm or 1000 mm
EMC test acc. to	DIN EN 60947-4-2 
Switching frequency	typ. 100 kHz



Connector Assignment

Cable assignment FIA-A-H-...

(4-wire cable, outer jacket PUR, shielded):

Color:	Assignment:
brown	+5V
green	ANALOG (0 ... +5V)
white	GND (0V)
yellow	I-CONTROL

Connector assignment FIA-A-H-...-P

(8-pole circular connector Binder 712):

Pin:	Assignment:
1	GND (0V)
2	+Ub
3	ANALOG (0 ... +5V)
4	I-CONTROL
5	n.c.
6	n.c.
7	n.c.
8	n.c.

Connector assignment FIA-A-H-...-TPN

(8-pole circular connector Binder 702):

Pin:	Assignment:
1	GND (0V)
2	+Ub
3	ANALOG (0 ... +5V)
4	I-CONTROL
5	n.c.
6	n.c.
7	n.c.
8	n.c.

Dimensions

FIA-A-H-....:

Fork size	Dim. A	Dim. B
10/10	10 mm	10 mm
10/15	10 mm	15 mm
10/20	10 mm	20 mm
10/30	10 mm	30 mm
15/10	15 mm	10 mm
20/10	20 mm	10 mm
20/30	20 mm	30 mm

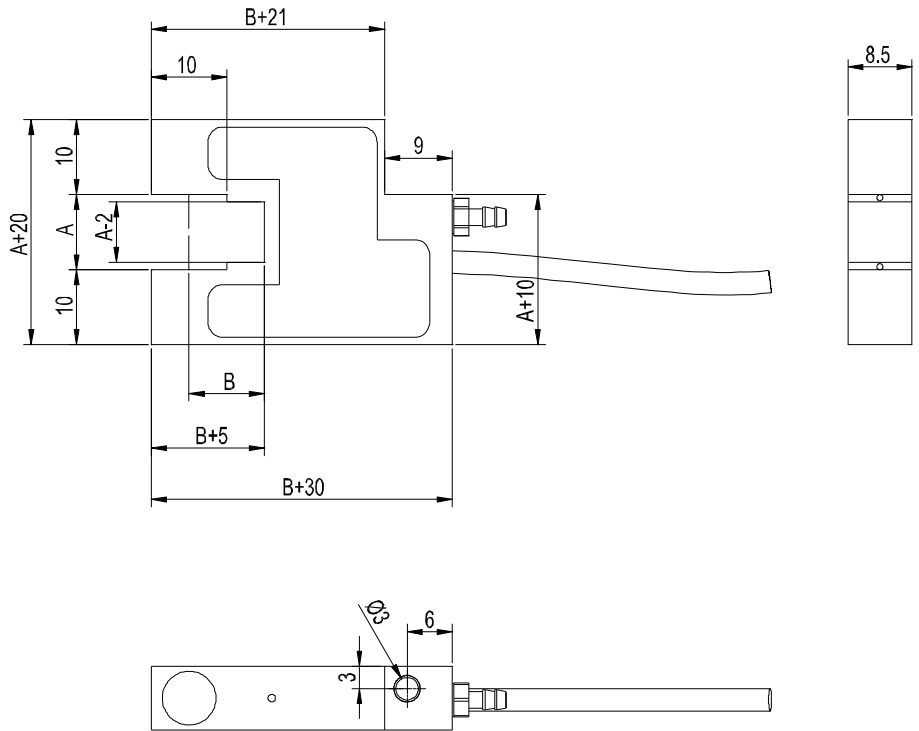

Tool plug TPN-01:

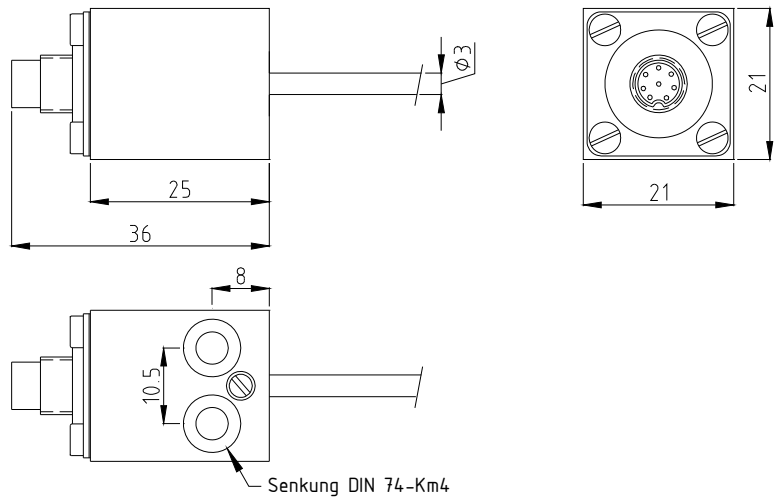
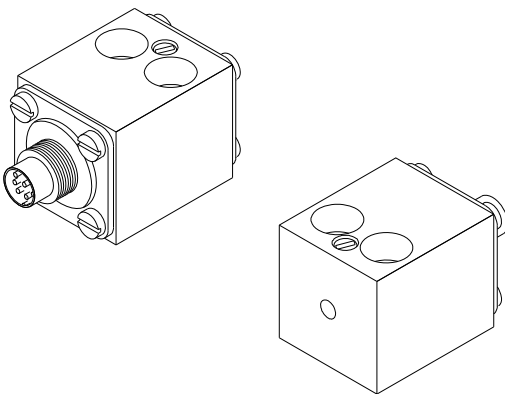

(All dimensions in mm)