

SI-JET Series

▶ SI-JET2-CON2 SI-JET2-FK-200/100-...

By way of the three optical fibers that are integrated in the transmitter and receiver branch, the SI-JET2 Spray Jet Monitoring System monitors the density and the symmetry around the opening angle of the spray jet. With the comprehensive SI-JET2-Scope software the system can be parameterised under Windows®.

- Telecentric design enables a big fork width
- Insensitive to dirt accumulation due to pressed air facility (at transmitter and receiver side of the fork)
- Averaging (over 32000 values)
- RS232 interface and Windows® user interface
- Teachable by means of integrated button, PLC, or PC)
- Insensitive to outside light due to clocked red light LED (100 kHz)
- High dynamic range (due to light power adjustment of LED via RS232)
- High resolution (12-bit-A/D-converter)
- Fiber optic fork can be used in areas subject to explosion hazards  (EX-RL, Zone 0)

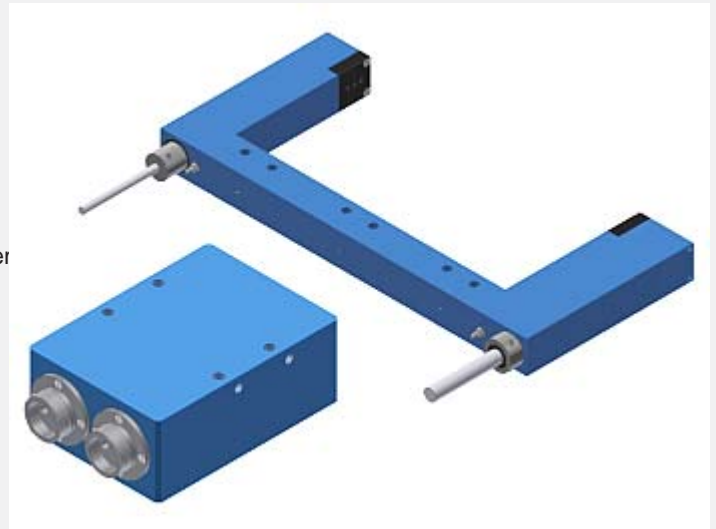

Product name:

SI-JET2-CON2

(Electronic control unit, incl. Windows® PC software SI-JET-Scope)

SI-JET2-FK-200/100-H

(Sensor frontend, optics horizontal, incl. fiber optics)

SI-JET2-FK-200/100-V

(Sensor frontend, optics vertical, incl. fiber optics)

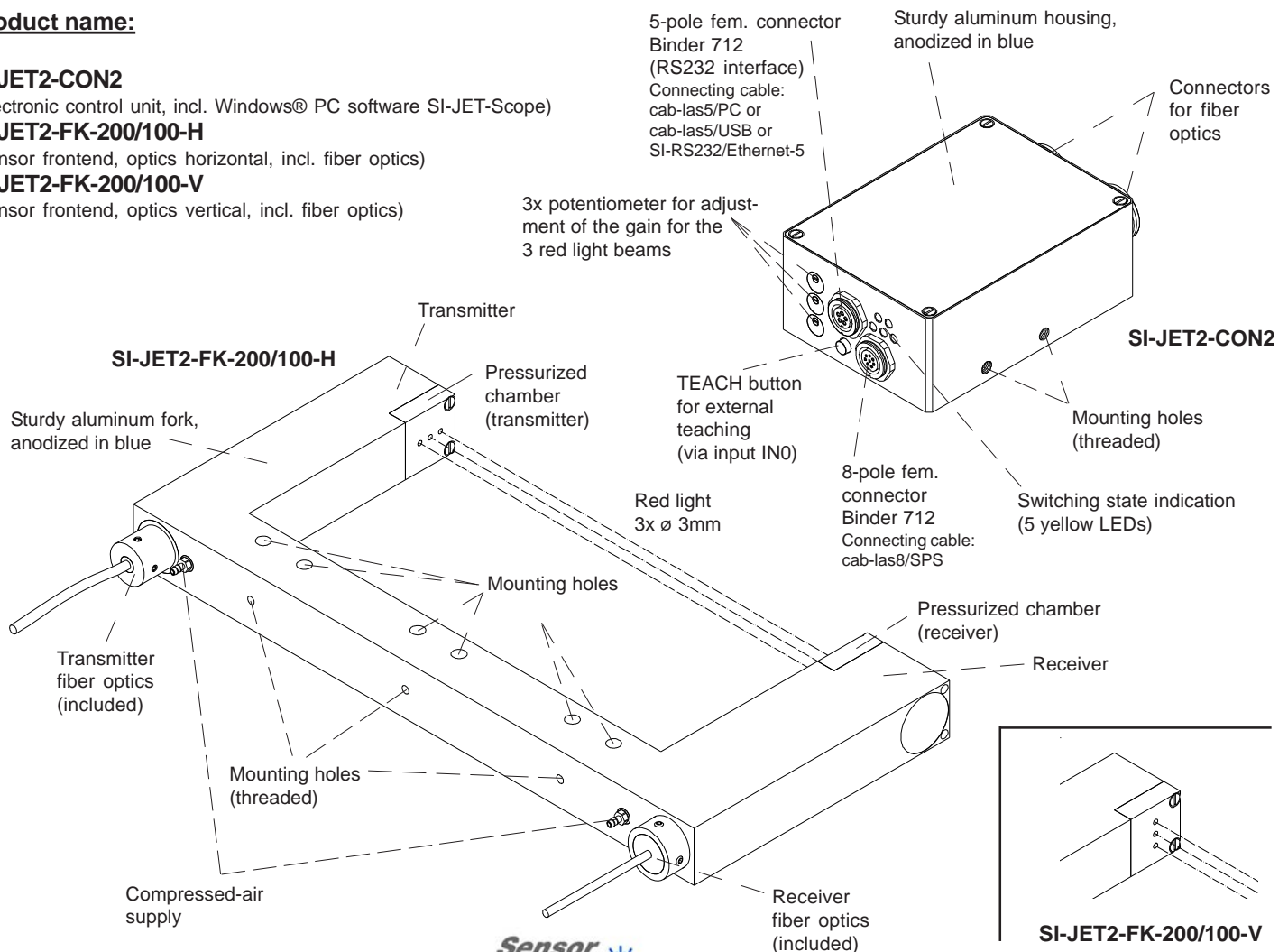



Technical Data

Model	SI-JET2-CON2 (electronic control unit)
Voltage supply	+24VDC (± 10%), reversed-polarity protected, overload protected
Current consumption	typ. 200 mA
Operating temperature	-10°C ... 50°C
Enclosure rating	IP64
Housing material	Aluminum, anodized in blue (fiber optics adaptor: aluminum, anodized in black)
Housing dimensions	approx. 90 mm x 65 mm x 35 mm (without flange connectors or fiber optics adaptors)
Type of connector	Connection to PC: 5-pole fem. connector Binder 712, connection to PLC: 8-pole female connector Binder 712 Connection to fiber optic frontends: 2-pole adaptor at transmitter side, 3-pole adaptor at receiver side
Transmitter	Super bright LED (red, 650 nm), modulated 100 kHz
External teaching	by means of an integrated push-button or via input IN0
Switching state indication	by means of 5 yellow LEDs
Interface	RS232, parameterizable under Windows®
Averaging	adjustable under Windows: max. 32768 values
Outputs	OUT0 ... OUT4, digital (0V/+U _B), short-circuit-proof, 100 mA max. switching current; npn- or pnp-capable (bright- and dark-switching can be adjusted)
External teach input IN0	+U _B -Signal (min. pulse length 250 ms, max. pulse length 1000 ms)
Pulse lengthening	adjustable under Windows®: 0 ms .. 100 ms
Spray values memory capacity	non-volatile EEPROM with parameter sets for max. 31 spray values
EMV test acc. to	DIN EN 60947-5-2

Model	SI-JET2-FK-200/100-... (fork, incl. fiber optics)
Fork width	200 mm
Red light beam alignment	telecentric, 3 x Ø 3 mm, distance between the beam bundles: 5 mm SI-JET2-FK-200/100-H: beam bundles arranged horizontally SI-JET2-FK-200/100-V: beam bundles arranged vertically
Optical filter	Red light filter RG630
Beam divergency	typ. 10 mrad
Enclosure rating	IP 67
Operating temperature range	-10°C ... +50°C
Storage temperature range	-20°C ... +85°C
Housing material	Aluminum, anodized in blue
Housing dimensions	approx. 272 mm x 124 mm x 24 mm
Fiber optics transmitter	2 fiber optic connectors, silicone metal sheath, length approx. 2000 mm
Fiber optics receiver	3 fiber optic connectors, silicone metal sheath, length approx. 2000 mm
Pressed air connector	at transmitter side and at receiver side



Sensor Frontend

SI-JET2-FK-200/100-H
(Sensor frontend, optics horizontal)

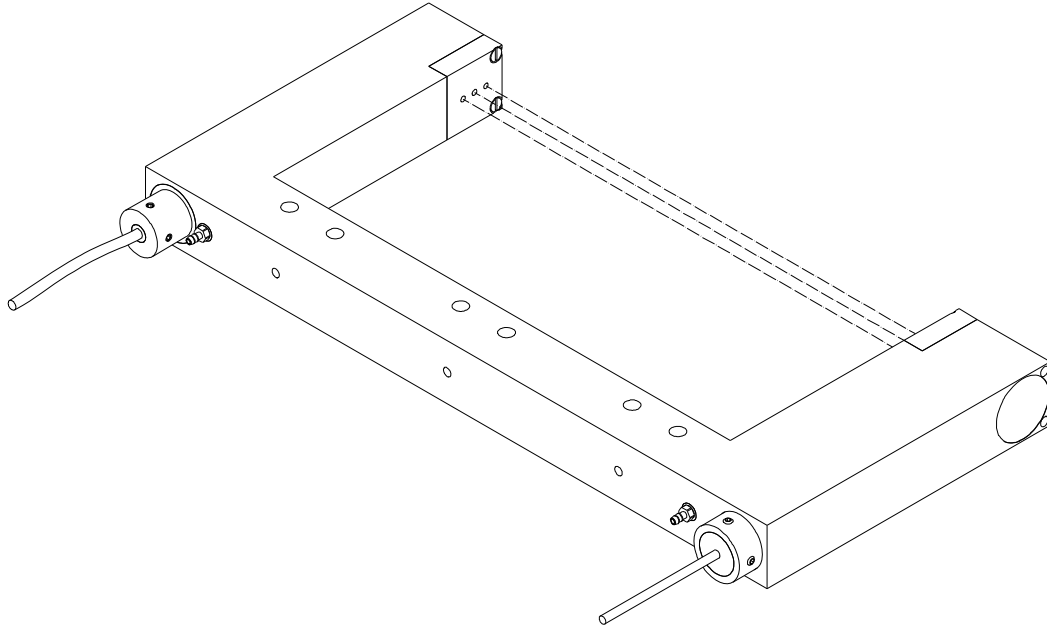

SI-JET2-FK-200/100-V
(Sensor frontend, optics vertical)

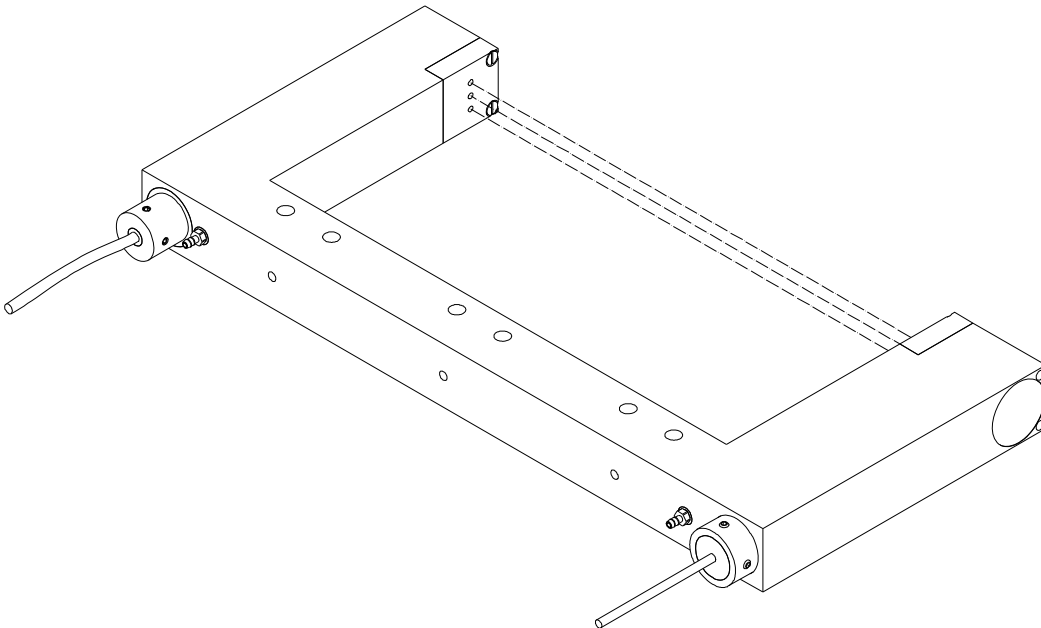



Dimensions

SI-JET2-FK-200/100-H

(Sensor frontend, optics horizontal)

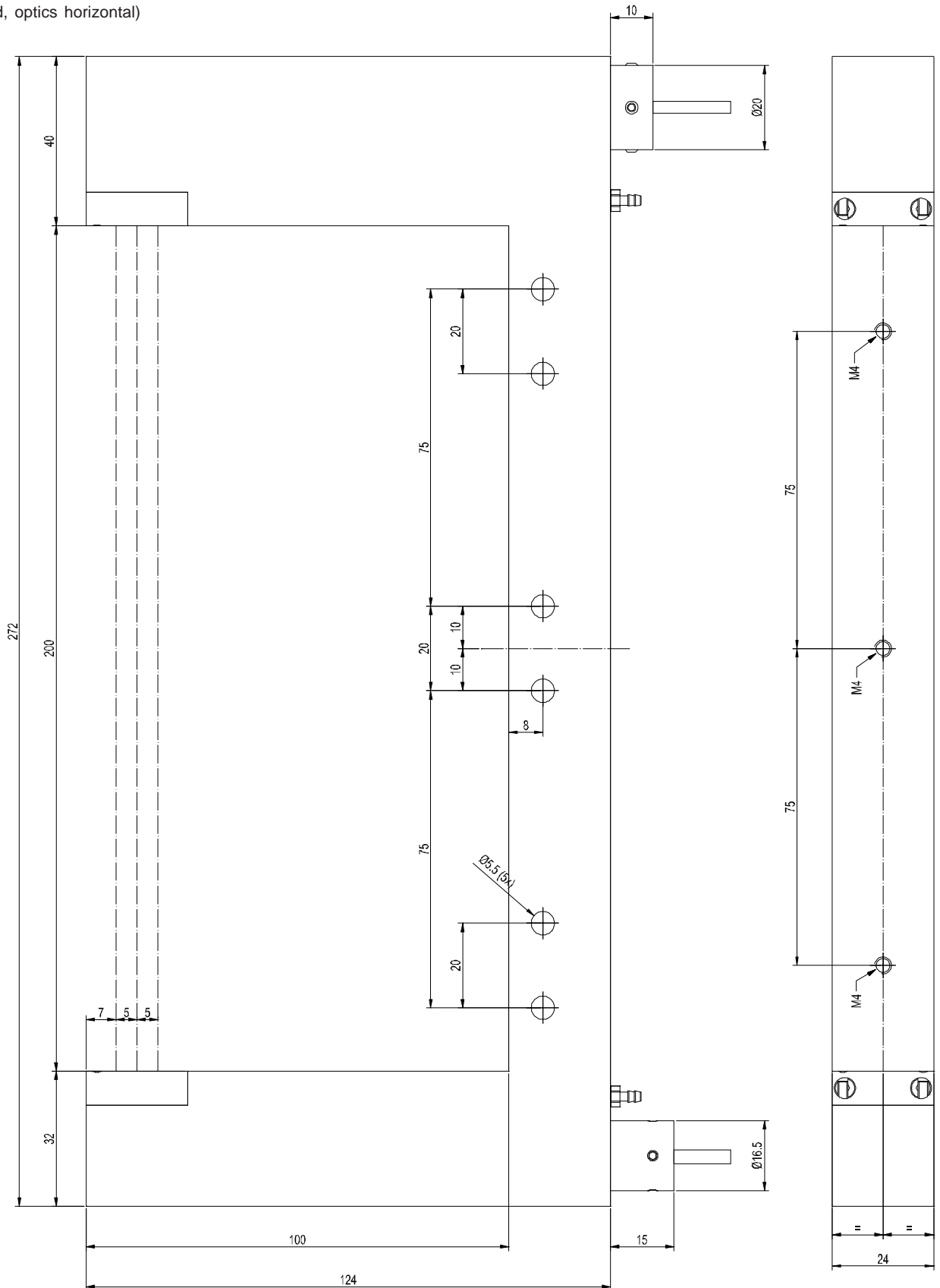

All dimensions in mm



Dimensions

SI-JET2-FK-200/100-V
(Sensor frontend, optics vertical)

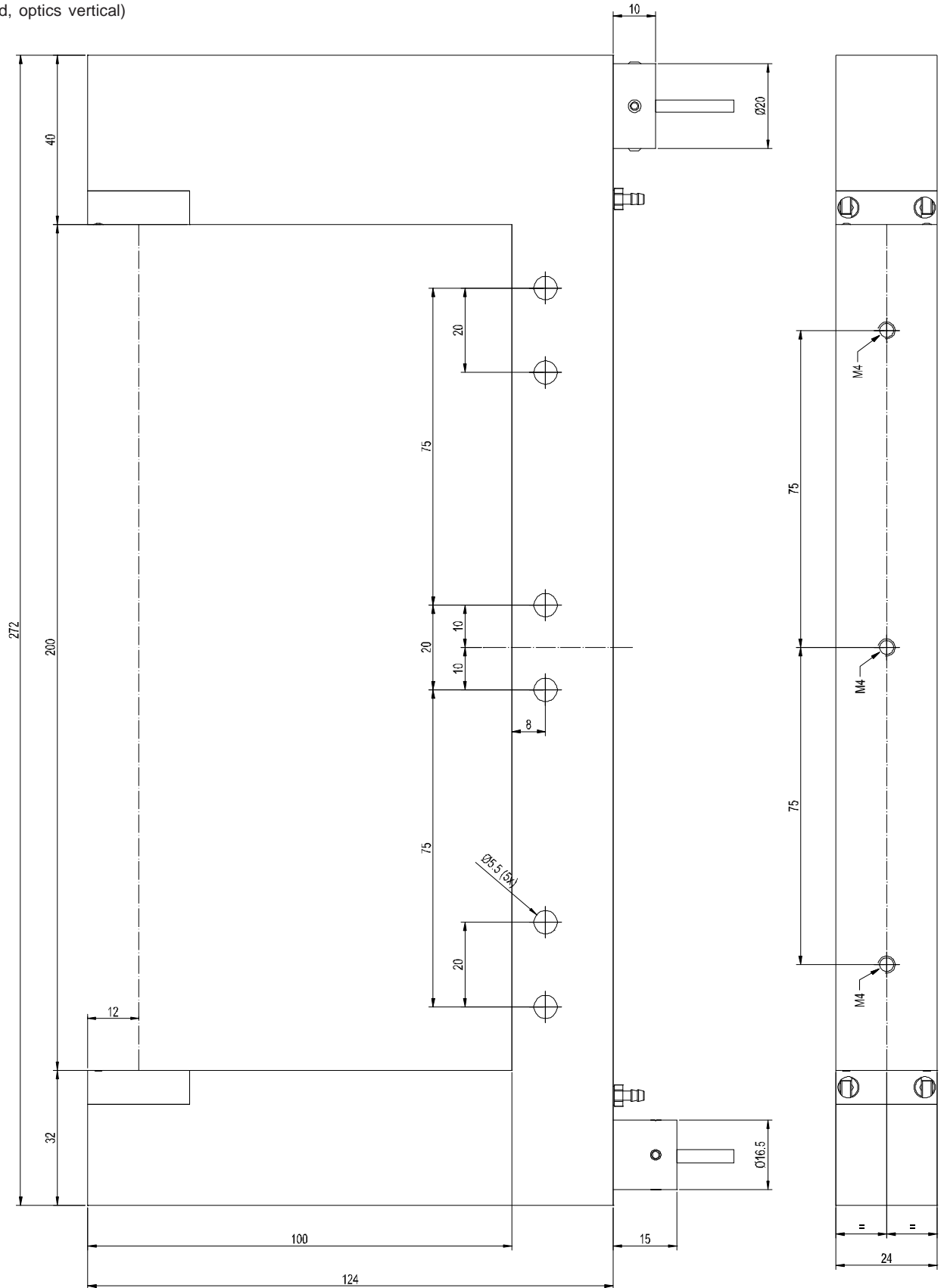

All dimensions in mm

Electronic Control Unit

SI-JET2-CON2
(Electronic control unit)

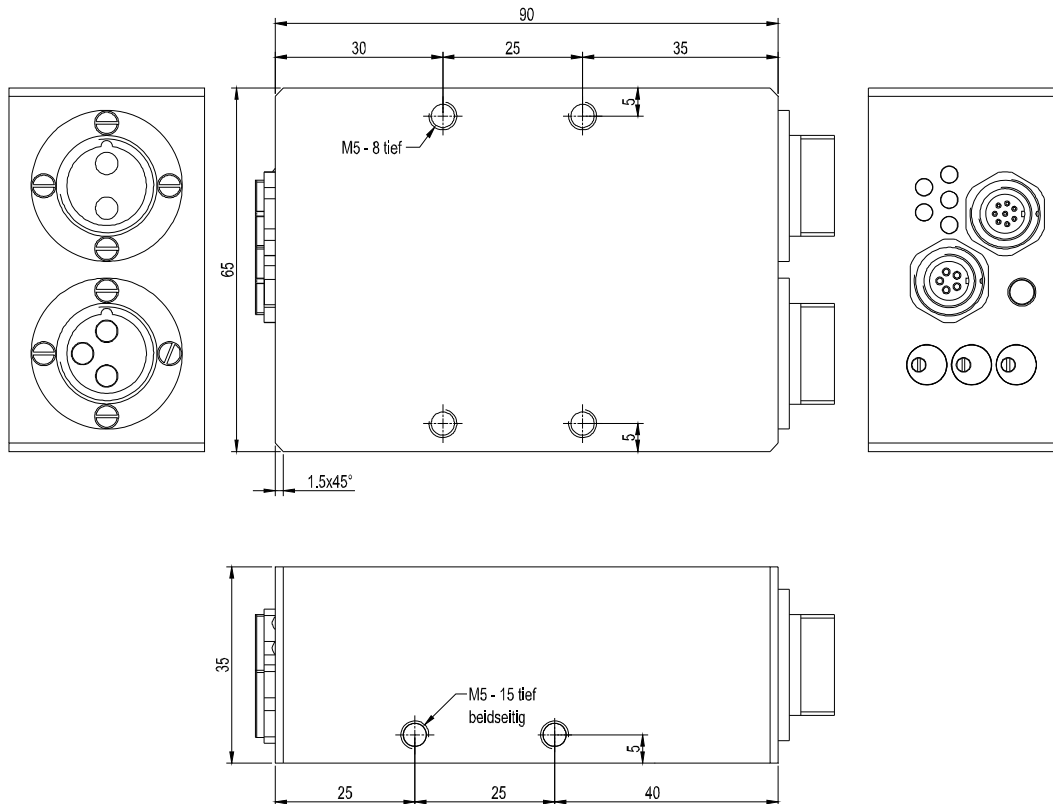
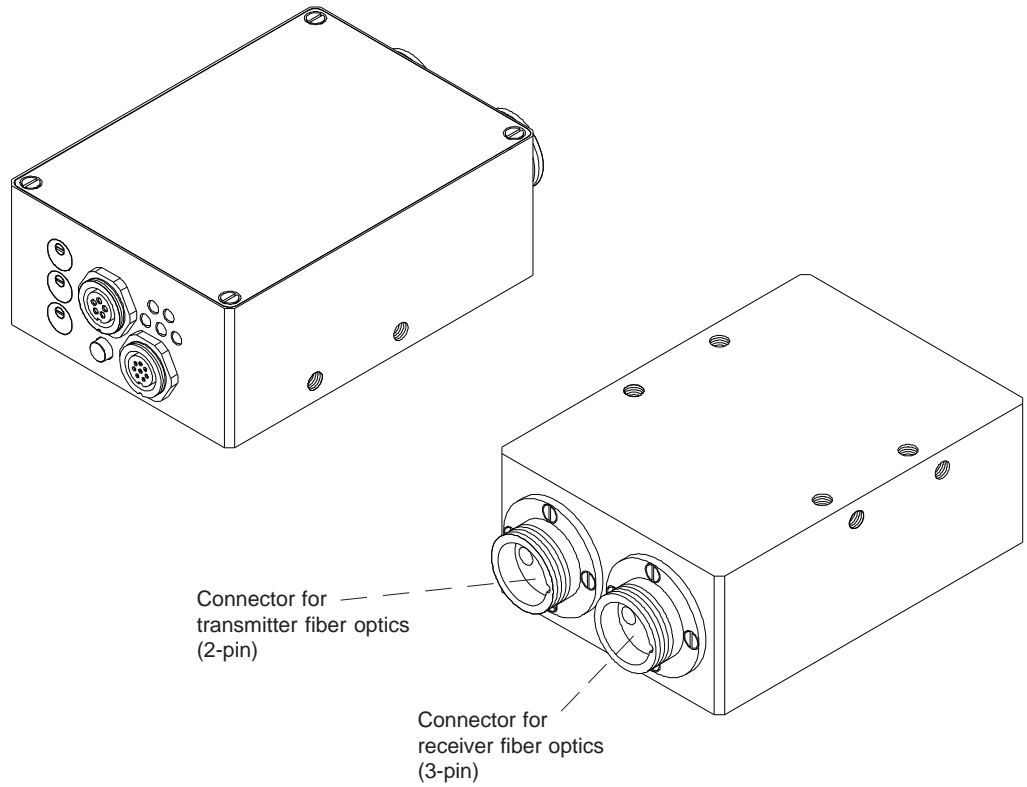

All dimensions in mm



Connector Assignment

**Connection SI-JET2-CON2 to PLC:
8-pole fem. connector Binder Series 712**

Pin:	Color:	Assignment:
1	white	GND (0V)
2	brown	+24VDC (±10%)
3	green	INO
4	yellow	OUT0
5	grey	OUT1
6	pink	OUT2
7	blue	OUT3
8	red	OUT4

Connecting cable:
cab-las8/SPS-(length)
cab-las8/SPS-w-(length) (angle type, 90°)
(standard length 2m)

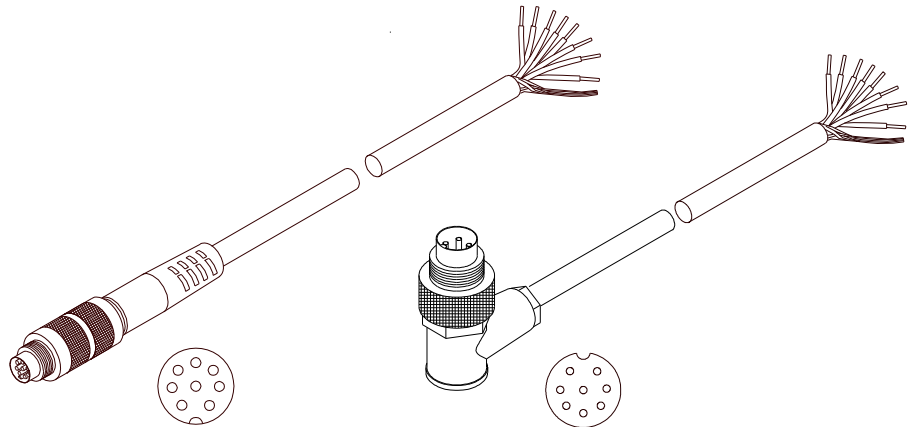

cab-las8/SPS-...
(max. length 25m, outer jacket: PUR)

cab-las8/SPS-w-...
(max. length 25m, outer jacket: PUR)

**Connection SI-JET2-CON2 to PC:
5-pole fem. connector Binder Series 712**

Pin:	Assignment:
1	GND (0V)
2	TxD
3	RxD
4	+24V (+Ub, OUT)
5	not connected

Connection via RS232 interface at the PC:
Connecting cable:
cab-las5/PC-(length)
cab-las5/PC-w-(length) (angle type 90°)
(standard length 2m)

alternative:
Connection via USB interface at the PC:
Connecting cable (incl. driver software):
cab-las5/USB-(length)
cab-las5/USB-w-(length) (angle type 90°)
(standard length 2m)

alternative:
Connection to local network via Ethernet bus:
Adapter (based on Lantronix XPortModul):
SI-RS232/Ethernet-5-(length)
(standard length 2m)

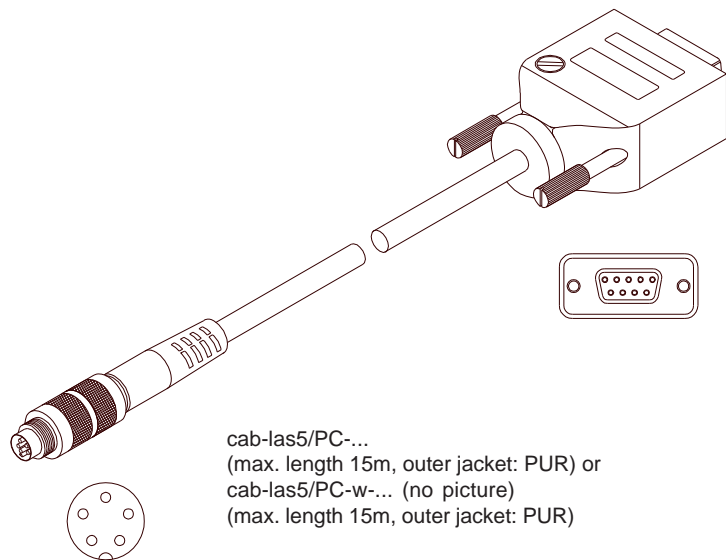

cab-las5/PC-...
(max. length 15m, outer jacket: PUR) or
cab-las5/PC-w-... (no picture)
(max. length 15m, outer jacket: PUR)

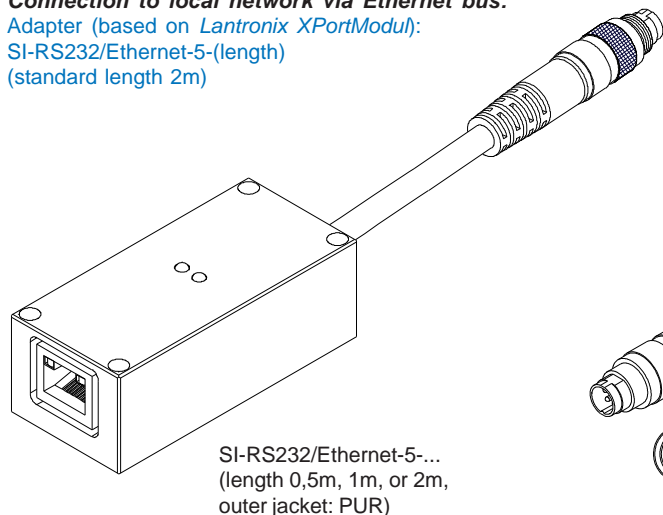

SI-RS232/Ethernet-5-...
(length 0,5m, 1m, or 2m,
outer jacket: PUR)

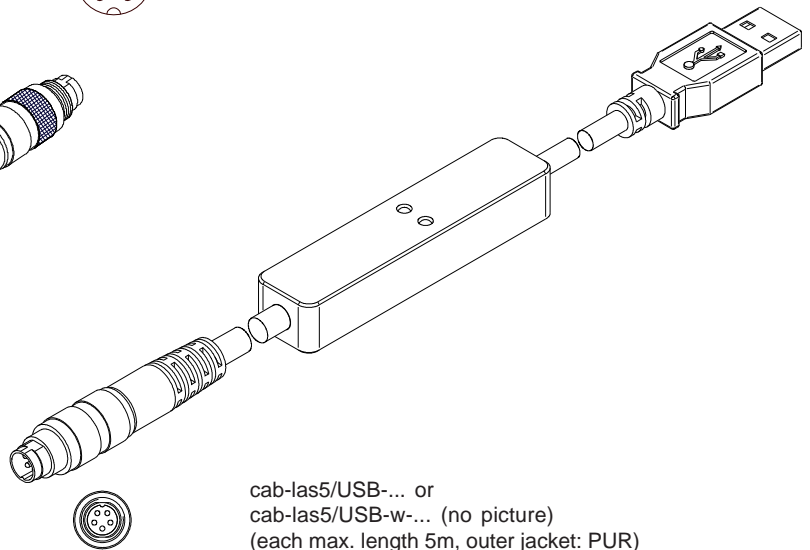

cab-las5/USB-... or
cab-las5/USB-w-... (no picture)
(each max. length 5m, outer jacket: PUR)



Settings

Potentiometer for adjustment of gain:



Clockwise rotation: Increase of signal

Adjustment of gain for the red light beam of CH_R (right)

Adjustment of gain for the red light beam of CH_C (center)

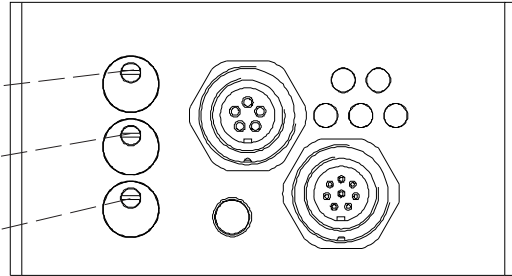
Adjustment of gain for the red light beam of CH_L (left)





Measuring Principle

With the help of a super-bright red-light LED modulated light is coupled in a transmitting optical-fiber and is aligned in parallel by means of a collimator optic unit that is integrated in the optical-fiber fork. A suitable aperture technology ensures that three beams of red light (\varnothing 3 mm each, 5 mm distance to each other) leave the transmitting branch of the transmitter, and at the receiving side are again directed onto three receiving optical-fibers by means of 3 apertures with suitable receiving optics.

By means of the optoelectronic detectors that are integrated in the receiving optical-fiber holder, the three light signals are converted into three electronic signals and are digitised by way of 12-bit-A/D-converters. When a spray jet now crosses the path of the three red light beams, the respective light beams are attenuated due to light absorption and/or light deflection at the droplets contained in the spray jet. The degree of attenuation of the respective signal is a measure for the droplet contraction at the place of the light beam.



Parameterization
Parameterization under Windows® with software SI-JET-Scope:

The following three measurands are picked up and monitored in the production process by the SI-JET2 spray jet monitoring system:

- Spray jet density (hereinafter referred to as density).
- Symmetry 1 (the two outer channels are put into proportion to each other).
- Symmetry 2 (Symmetry 1 is put into proportion to the centre channel).

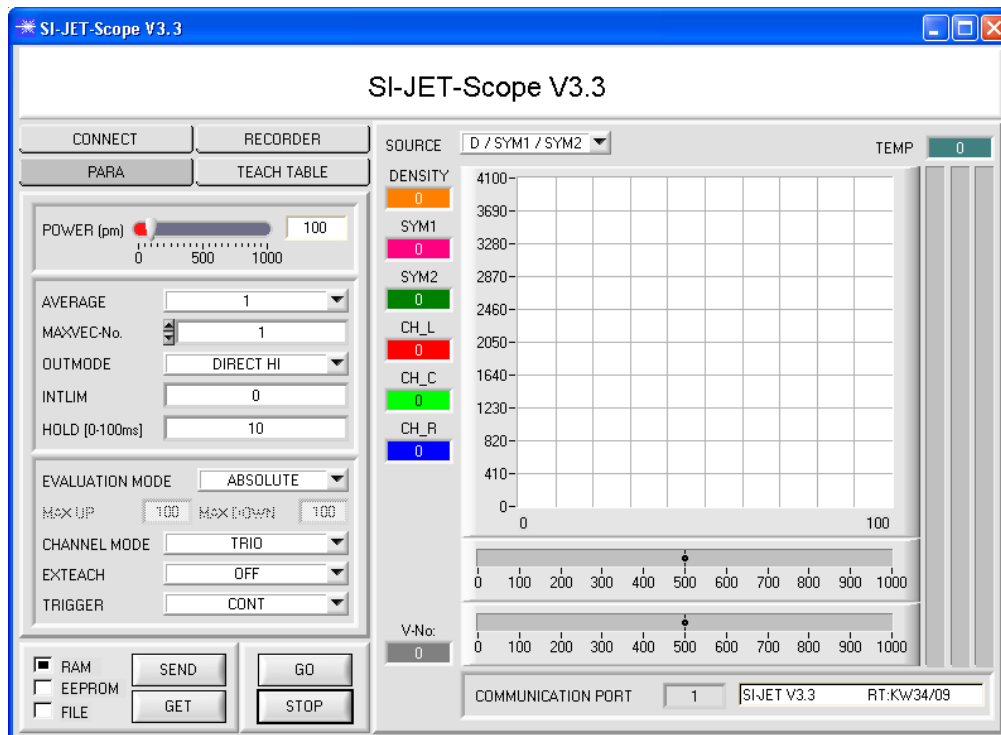
Evaluation modes:

The SI-JET2 can be operated with two different evaluation modes.

ABSOLUTE: The absolute status of the three channels CH_L, CH_C, and CH_R is used for evaluation.

RELATIVE: The current status of the three channels CH_L, CH_C, and CH_R relative to their maximum values in the last 60 seconds is used for evaluation.

TEACH process:

The teach process can be performed either with the parameterisation software, by way of the teach input (IN0 PIN3 green at the cab-las8/SPS cable), or by means of the switch at the housing. When teaching is performed through the IN0 input, the tolerance values for density and symmetry must first be stored once in the EEPROM of the control unit with the help of the parameterisation software. Before input IN0 is activated, the status to be taught must be present at the sensor front-end, i.e. spraying must first be switched on, and then IN0 must be set to +24V.

The current status is taught to as many rows in the Teach Table as have been selected under MAXVEC-No. Classification is performed by way of different set tolerances.



LED Display

LED display:

The line vector is visualised by way of 5 yellow LEDs at the housing of the SI-JET2 sensor. At the same time in the BINARY mode (OUTMODE BINARY) the line vector indicated on the LED display is output as 5-bit binary information at the digital outputs OUT0 to OUT4 of the 8-pole SI-JET2/PLC female connector.

The SI-JET2 sensor is able to process a maximum of 31 line vectors (0 ... 30) in accordance with the corresponding lines in the TEACH TABLE. An "error" or a "not detected" is displayed by the lighting of all LED (OUT0 ... OUT4) digital outputs are set to HIGH-level).

In the DIRECT mode (OUTMODE DIRECT HI or OUTMODE DIRECT LO) the maximum numbers of line vectors to be taught is 5 (no. 0, 1, 2, 3,4).

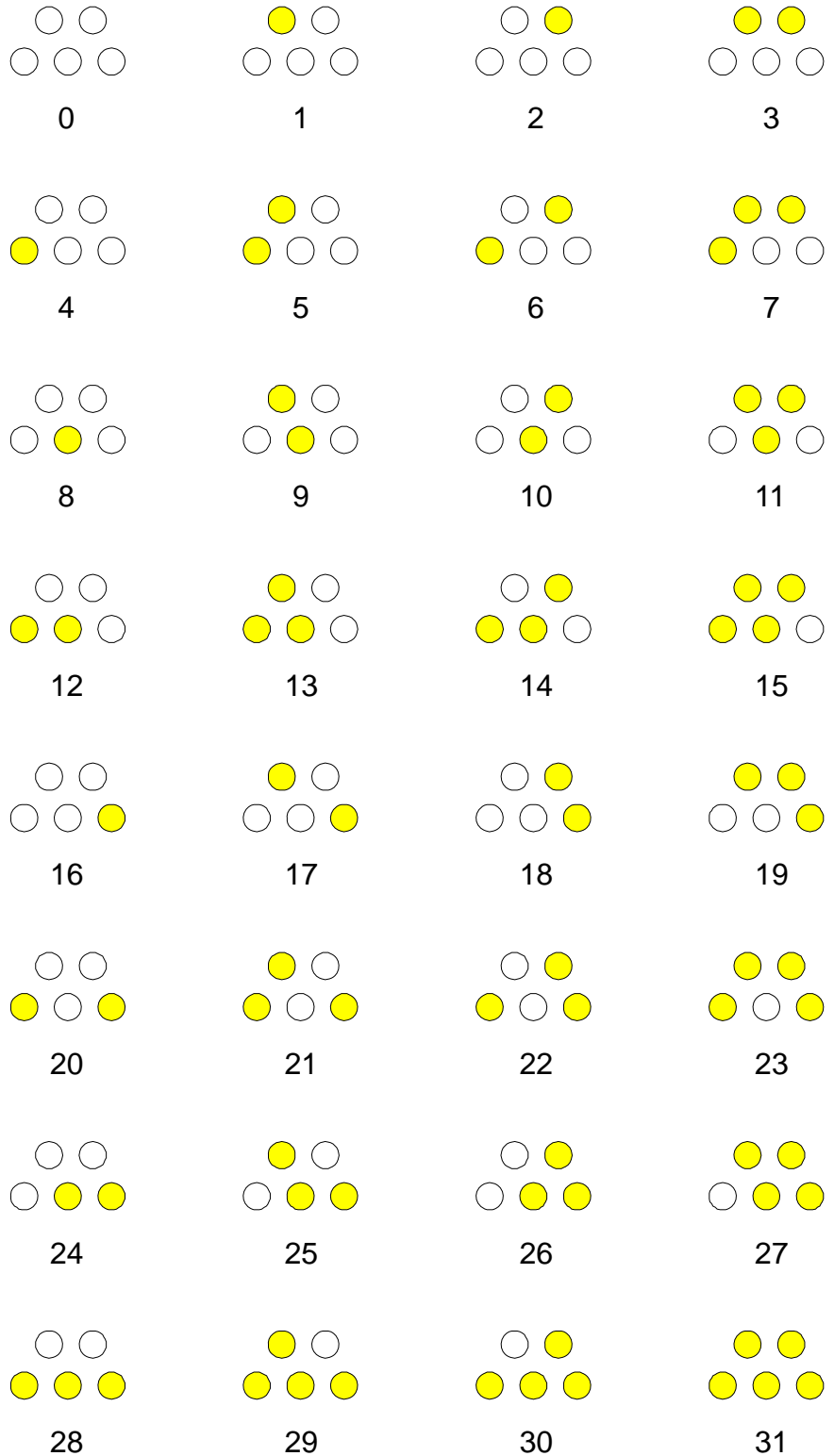

„Error“
or
„not detected“

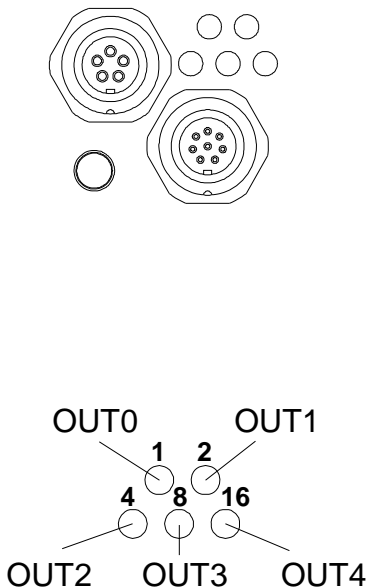

 Data Recorder
Function of the data recorder:

The SI-JET2-Scope software features a data recorder that makes it possible to save a certain number of data frames. The recorded file is saved to the hard disk of the PC and can then be evaluated with a spreadsheet program.

The created file has eight columns and as many rows as data frames were recorded. A row is structured as follows: Date and time, CH_L, CH_C, CH_R, DENSITY, SYM1, SYM2, TEMP.

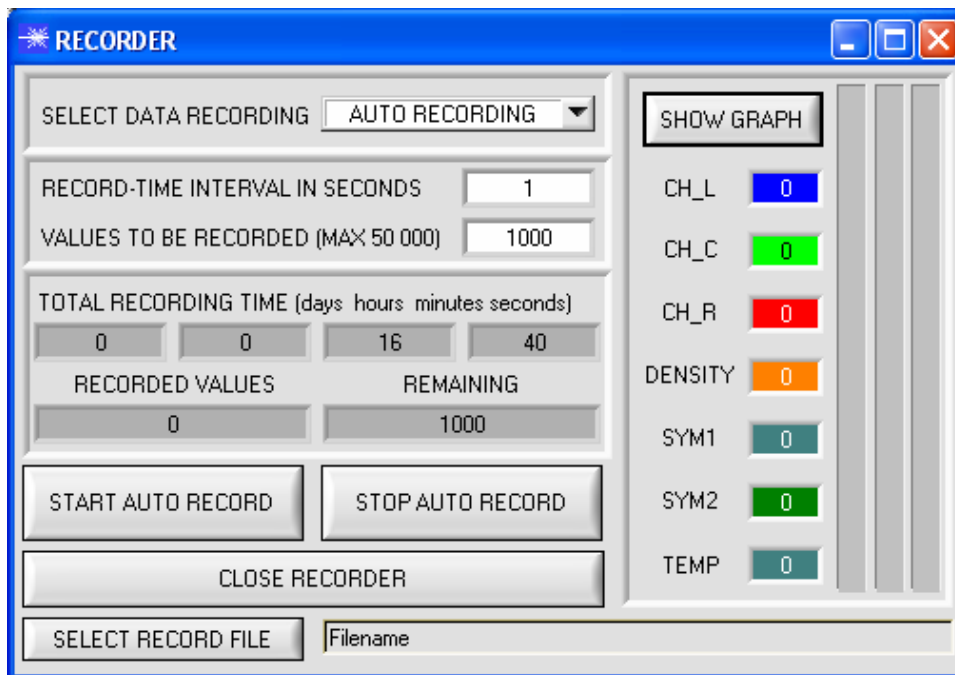

 Application Example
Monitoring of the spray jet cone

Three parallel aligned red light bundles will be compared to each other.

The following three measuring values will be calculated and monitored during the production process:

- Density (DENSITY)
- Symmetry 1 (SYM1)
- Symmetry 2 (SYM2)

